

*hr*<sub>nr</sub>

focus  
on  
communications  
technology . . .

# ham radio

MARCH 1968

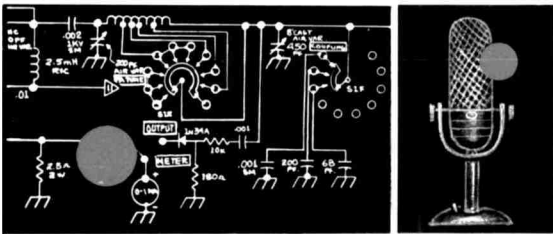
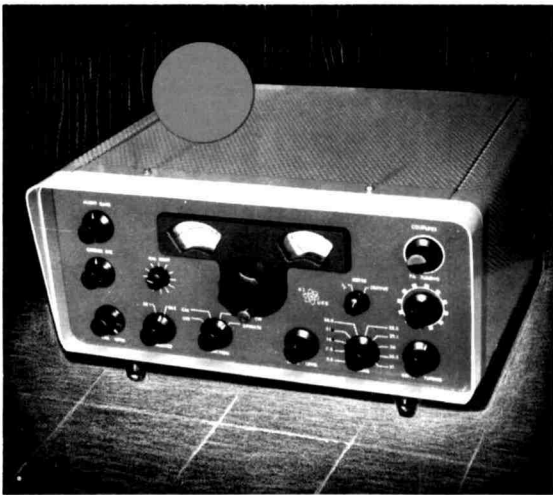

## *this month*

- IC-regulated power supply 28
- remotely-tuned 10-meter beam 32
- curve master transistor curve tracer 40
- double-balanced mixers 48

## *special section*

- homebrew 5-band SSB exciter  
complete construction details



# HERE'S THE "BARGAIN BIBLE"— the Catalog you've been waiting for!

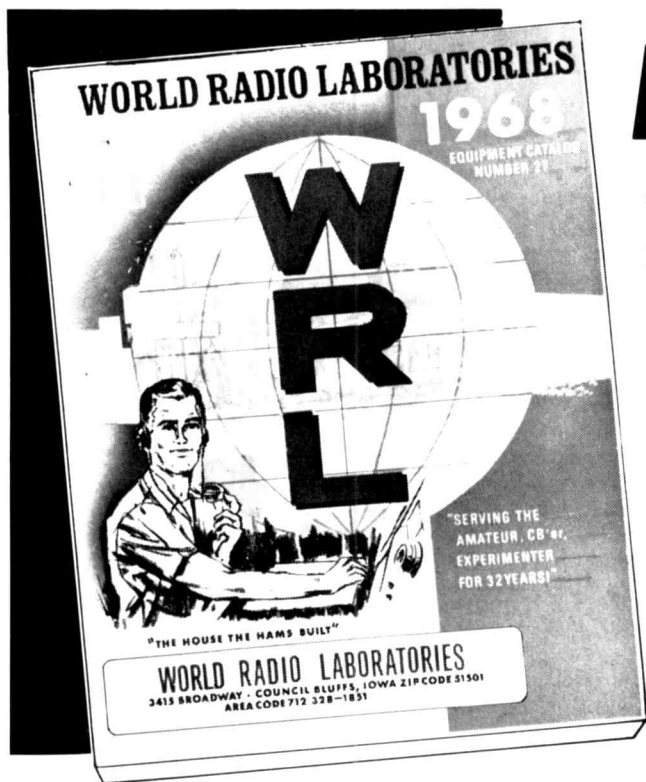

# FREE!

## JUST MAIL IN COUPON!

**ALL NEW!** Page after page of exciting equipment and accessories at money-saving prices.

- **EXCITING NEW FEATURE!** Complete Amateur Station "Packages" selected by WRL electronic experts! The best buys—each combination Performance Proven! Low monthly payments available on all pkgs.
- Selected "Best Buys" on other equipment — radios, recorders, stereos, items for Electronic Builders and Gadgeteers.
- **SPECIAL WRL PURCHASES!** Equipment you can't BUY anywhere else!
- The most complete Amateur Catalog ever put together. Detailed illustrations, complete specifications. Save at WRL's amazing low prices!
- **LIBERAL TRADE-INS** on your present gear . . . and you can buy anything in this big, new catalog on our easy, monthly credit plan!

From WRL—the largest, most personalized Radio Supply House in the World! Over 30 licensed operators among our 95 employees to assist you in any way possible.

CLIP AND MAIL THIS COUPON FOR YOUR COPY

"The House the HAMS Built"

### WORLD RADIO LABORATORIES

3415 West Broadway  
Council Bluffs, Iowa 51501

Key Number  
HR-Z2

Gentlemen:

Please rush me my FREE 1968 WRL Catalog of Bargains.

Name \_\_\_\_\_

Address \_\_\_\_\_

City \_\_\_\_\_ State \_\_\_\_\_ Zip \_\_\_\_\_



# 10 reasons to buy Hallicrafters' new SR-400 Cyclone

| FEATURE                                | Hallicrafters SR-400          | Collins* KWM-2A               | Drake* TR-4A                  |
|--|-------------------------------|-------------------------------|-------------------------------|
| Power Input                            | SSB=400 watts<br>CW=360 watts | SSB=175 watts<br>CW=150 watts | SSB=300 watts<br>CW=260 watts |
| Accessory "dual receive" VFO available | Yes                           | No                            | No                            |
| Noise Blanker                          | Yes                           | \$135.00<br>Accessory         | No                            |
| Receiver Incremental Tuning            | Yes                           | No                            | No                            |
| Built-in notch Filter                  | Yes                           | No                            | No                            |
| Sharp CW Filter                        | Yes<br>200 cycles             | No                            | No                            |
| Sensitivity                            | .3 uv for<br>10 db S/N        | .5 uv for<br>10 db S/N        | .5 uv for<br>10 db S/N        |
| 1 kHz dial readout                     | Yes                           | Yes                           | No                            |
| Carrier Suppression                    | 60 db                         | 50 db                         | 50 db                         |
| Unit Price                             | <b>\$799.95</b>               | <b>\$1,150.00</b>             | <b>\$599.95</b>               |

\*Data from published specifications.

## Now: can you think of one reason why you shouldn't?

Superb sensitivity, 400 watts RF, 200 cycle CW selectivity, receiver incremental tuning, 1 kHz readout, amplified automatic level control, exclusive notch filter! There's even the HA-20 dual receive VFO for sensational, award winning DX operation. No matter what specifications or features you choose as a standard of comparison, the exciting new SR-400 fixed/mobile transceiver is unsurpassed. Unsurpassed feature for feature. Unsurpassed for rugged dependable performance in all environments. Unsurpassed in value and versatility. Prove it to yourself. Write for complete specifications in a four page brochure. See your Hallicrafters' distributor today.



### hallicrafters

600 Hicks Rd., Rolling Meadows 60008

A Subsidiary of Northrop Corporation

SR-400 Cyclone Transceiver

HA-20 VFO

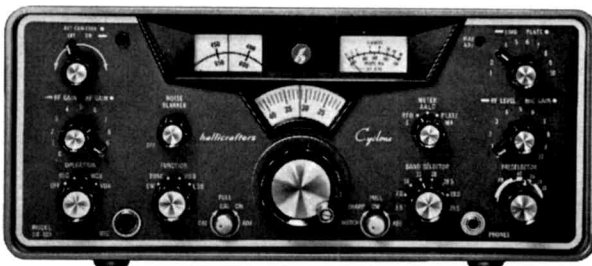

Export: International Dept. Canada: Gould Sales Co.

# NEW Drake R4B Receiver



Amateur Net **\$430<sup>00</sup>**

\*Linear permeability tuned VFO with 1 kc dial divisions. VFO and crystal frequencies pre-mixed for all-band stability • Covers ham bands 80, 40, 20, 15 meters completely and 28.5 to 29.0 Mc of 10 meters with crystals furnished • Any ten 500 kc ranges between 1.5 and 30 Mc can be covered with accessory crystals for 160 meters, MARS, etc. (5.0-6.0 Mc not recommended) • Four bandwidths of selectivity, 0.4 kc, 1.2 kc, 2.4 kc and 4.8 kc • Passband tuning gives sideband selection, without retuning • Noise blanker that works on CW, SSB, and AM is built-in • Notch filter and crystal calibrator are built-in • Product detector for SSB/CW, diode detector for AM • Crystal Lattice Filter gives superior cross modulation and overload characteristics • AVC for SSB or high-speed break-in CW • Dimensions: 5½" H, 10¾" W, 12¼" D. Wt.: 16 lbs.

Same specifications as R4A\*

## PLUS

- New tuning knob and skirt
- PTO indicator light
- Side-mounted head phone jack
- New scratch-proof epoxy finish
- New eye-ease front panel
- Improved audio  
(low distortion, high output)
- SOLID STATE circuitry used in PTO, Crystal Oscillator, Product Detector, AVC Circuit, BFO, Audio Amplifier, Crystal Calibrator.

25KC Calibrator has a sophisticated design, using integrated circuits and FET's; permits working closer to band edges.

The R-4B RECEIVER is a model of design, using the best combination of transistors and tubes, printed circuits and hand wiring to give maximum performance and minimum maintenance, at the lowest cost.

## NEW DRAKE ACCESSORIES



**WATTMETER  
W-4 \$49<sup>50</sup>**

Reads forward and reflected power directly in watts (VSWR from nomogram). Two scales in each direction. 200 and 2000 watts full scale. Calibration accuracy ± (5% of reading + 2 watts) on 200 watt scale; ± (5% of reading + 20 watts) on 2000 watt scale. Size: 5½" H x 3¾" W x 4" D.



**MN-4... \$90.00**  
200 watts



**MN-2000... \$160.00**  
2000 watts PEP

## MATCHING NETWORKS

**General:** With integral VSWR meter and RF wattmeter. Matches 50 ohm resistive transmitter output to coax antenna feedline with VSWR of up to at least 5:1 whether resistive, capacitive or inductive. Covers ham bands 80 thru 10 meters. Has alternate output for tuning up into external dummy load. Meter reads forward power directly and VSWR directly, or can be calibrated to read reflected power directly in watts. Size: 5½" H x 10¾" W x 8" D. Matching network can be switched in or out with front panel switch.

**Continuous Duty Output:** MN-4, 200 watts; MN-2000, 1000 watts (2000 watts PEP).

**Meter reads forward power directly:** MN-4, 300 watts full scale with accuracy ± (5% of reading + 3 watts); MN-2000, 2000 watts full scale with accuracy ± (5% of reading + 20 watts), and 200 watts full scale with accuracy ± (5% of reading + 2 watts).

**MN-2000 only:** Up to 3 antenna connectors can be selected by front panel switch.

Prices and specifications subject to change without notice.

See your distributor. For more information write to:

**R. L. DRAKE COMPANY • MIAMISBURG, OHIO 45342**

Attn: Dept. 127



# ham radio

## staff

### editor

James R. Fisk,  
W1DTY

### roving editor

Forest H. Belt

### associate editors

A. Norman Into, Jr.,  
W1CCZ/K2IEO

Nicholas D. Skeer,  
K1PSR

James A. Harvey,  
WA6IAK

### art director

Jean Frey

### publisher

T. H. Tenney, Jr.,  
W1NLB

## offices

Greenville, New Hampshire 03048  
Telephone: 603-878-1441

**ham radio** is published monthly by Communications Technology, Inc., Greenville, New Hampshire 03048. Subscription rates: U.S.A. and Canada, one year, \$5.00, three years, \$10.00. Copyright 1968 by Communications Technology, Inc. Title registered at U.S. Patent Office. Printed in Montpelier, Vermont 05602, U.S.A.

Postmaster: Please send form 3579 to **ham radio**, Greenville, New Hampshire 03048.

First printing  
February 1968—  
30,000 copies

Second printing  
September 1968—  
5,000 copies

## contents

|  |                    |
|--|--------------------|
| Homebrew 5-Band SSB Exciter<br>Fred S. Randall, K1UKX                | 10                 |
| FET Converters for 50, 144, 220 and 432 MHz<br>Frank C. Jones, W6AJF | 20                 |
| IC-Regulated Power Supplies<br>Henry D. Olson, W6GXN                 | 28                 |
| Remotely-Tuned 10-Meter Beam<br>George A. Cousins, VE1TG             | 32                 |
| Curve Master Transistor Curve Tracer<br>J. Tom Lamb, K8ERV           | 40                 |
| Double-Balanced Mixers<br>James R. Fisk, W1DTY                       | 48                 |
| The 3-500Z in Amateur Service<br>William I. Orr, W6SAI               | 56                 |
| Pre-Con—A Precision Capacitor<br>E. L. Klein, W4BRS                  | 61                 |
| A Beginner's Guide to Single Sideband<br>Forest H. Belt              | 66                 |
| For That Professional Look<br>Michael J. Goldstein, VE3GFN           | 74                 |
| Whips and Loops as Apartment Antennas<br>John J. Schultz, W2EEY      | 80                 |
| The Drake W-4 Wattmeter<br>James R. Fisk, W1DTY                      | 86                 |
| The James Research Oscillator/Monitor<br>James R. Fisk, W1DTY        | 91                 |
| <b>departments</b>   |                    |
| A Second Look      4   | Here We Are      6 |
| Advertisers Index    96  | Next Month      79 |

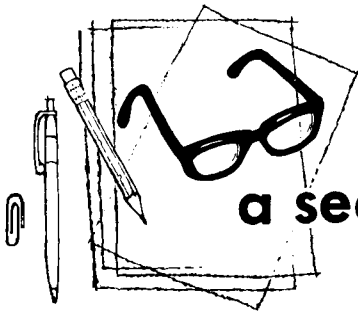

## a second look

by jim  
fisk

The birth of a magazine is a complicated process. It starts as an idea and develops through the coordinated efforts of authors, artists, typographers and pressmen. The ingredients are varied: articles, schematics, long-distance telephone calls, photography, advertising, subscriptions, public relations, paper and ink, all lovingly stirred together with prodigious amounts of midnight oil. Name: **ham radio**, born January, 1968.

Why **ham radio**? Very simple. The electronics and communications industry is moving forward at a tremendous clip, and so is amateur radio. Single sideband has largely replaced a-m, transistors are taking the place of vacuum tubes, and integrated circuits are finding their way into the ham workshop. The problem today, as it has always been, is to keep the amateur well informed. This doesn't mean that you have to impress your readers by printing every piece of state-of-the-art news that appears on the horizon.

Quite to the contrary. If you limit yourself to the state of the art, you'll get lost in a hurry. Advances are being made so rapidly, you just get tuned in and there's something new to worry about. And, since each new advance is built on what has been done in the past, if you don't get a clear idea of present techniques, you'll be hopelessly lost as time goes on.

Transistors have been with us for fifteen years, but it has just been within the last year or so that hams have started really thinking in terms of solid state. True, you usually wait

for that old vacuum-tube equipment to wear out before replacing it with solid-state gear, but many of the little gizmos around the shack that you've put together in the past few years should be transistorized. Are they? Probably not.

When vacuum tubes became practical devices, amateurs were among the first to use them in home construction. Likewise with semiconductor diodes. Not so with Transistors. Why? Because hams didn't have enough good **practical** information to go by. Unfortunately, transistors blow out a lot easier than tubes, and many amateurs who experimented with them in the early days were disillusioned by a row of "dead soldiers" on their bench.

What it amounts to is this. There is an awful lot of state-of-the-art practice which you've got to understand before you get into state-of-the-art design. If you're an engineer, fine, but not all hams are engineers. Most hams want practical circuits which they can adapt to their special jobs.

As an example of where this state-of-the-art phobia has taken us, consider single sideband for a moment. I would guess that at least 80% of the hams operating on our lower bands are using single-sideband equipment. But how many of them actually understand what goes on inside that box? Not nearly enough!

The problem here is that ssb appears to be a lot more complex than a-m. Certainly the gear required to generate a ssb signal is more complex than that old a-m rig, but under-

standing what makes it tick is not. The two modes are very closely related. Not particularly compatible, but related. The problem is that a simple, concise explanation of sideband has been lacking. Several excellent articles along this line were written in the early fifties, but many of the hams who have sideband equipment now have never seen them.

**Ham radio** is designed to fill this gap. It is designed to inform. It will be geared to the state of the art—the state of the art in practice. It will be a magazine which shows you how to use new devices and old. Although we will encourage the use of solid state, we will not discriminate against vacuum tubes for the sake of being modern. There are a lot of places where vacuum tubes are still very practical and desirable gadgets.

When new techniques and devices become available, look for a complete description of how to use them in **ham radio**. Our articles will run the gamut from the simple to the complex, but they will all be oriented to the practical approach—the amateur approach. Not all of you are interested in the same things, nor do you have similar electronic backgrounds, so the fare served up in **ham radio** will be varied.

We will have simple projects for the novice and the one-night-a-week experimenter, involved projects for the experienced ham who likes to work in his shop, practical design and theory articles for the fellow who wants to start from scratch, and the last word for the VHF'er, RTTY bug and ATV enthusiast.

Amateur radio, just by its nature, is a very diversified hobby. Each ham follows his own special interests, whether home construction, public service, DX, traffic or a multitude of others. If you don't see an article that covers your particular plane of interest, it's because no one has taken the time to write it. If you have a little gimcrack that you've just put together, and think others would be interested in what it can do, draw a schematic, take some pictures and write it up. You don't have to be a professional writer to get your name in print; most of ours are not.

In addition to full-length feature articles, we are in the market for shorties for the **ham notebook**. If you have found a new and better

way of doing something in the shack, have a new construction wrinkle, or have some small gem of technical information to convey, send it in to **ham notebook**. This monthly feature will cover everything from **Antennas** to **Zener diodes**, construction and design—technical tips that are useful around the shack and shop. You'll get paid for your efforts, and the rest of our readers will benefit from your ingenuity.

If you're interested in contributing something to **ham radio**, write for our "Author's Guide." This handy little pamphlet shows how to put your story together, the essentials of clear writing, the abbreviations we use, and what we need in terms of schematics and photographs. It also outlines our rates and payment policy.

Payments for manuscripts are generous and immediate. If we like your article, you'll get a check with our letter of acceptance, usually within a week of when you put it in the mail. After we accept it, it won't sit in our files for months or years waiting for publication. It will be put into print just as soon as possible. Articles that sit in the file are no good to the reader, to the author or to us. Nobody wants to read about (or build) a VHF converter today that was the hottest thing on two wheels when it was originally designed three years ago!

**Ham radio** will not stand still. We will always be looking for ways to improve because amateur radio is a dynamic hobby, always on the move. As the equipment, techniques and challenges of amateur radio change, so will we. We'll constantly try to make **ham radio** more useful to you as well as more interesting and stimulating. We can promise you now, we'll never become complacent, we'll always try to make **ham radio** better.

**Jim Fisk W1DTY**  
Editor

**Note:** If you received more than one copy of this first issue of **ham radio**, don't worry about it—it simply means that you're an active amateur and your name has appeared on more than one of our mailing lists. Just give the extra copy to a friend who hasn't seen it.

# here we are

## a word from the publisher

Here we are! It's been a long trip since early October when Jim and I decided that there was definitely a place for **ham radio**. Where will the money come from? What will we call it? What will it look like? How will we get subscribers? How will we obtain advertisers? All of these questions, and many more, had to be answered one by one as **ham radio** began to take the final shape that you see here.

It has not been an easy road. We did not expect it to be. However, there have been many unexpected rewards along the way as many folks, both individual amateurs and those in industry, have given us valuable support and encouragement. We quickly found that there were many others who felt just as strongly as we that our magazine would be quite useful to the amateur community.

Can amateur radio really support a new magazine? We think it can, and here are some reasons why: Much has been said in recent years about what is wrong with our hobby, but altogether too little about what is healthy and right about it. We feel that amateur radio is a healthy patient and that it is going to be with us for a long time to come. Let's face it, we wouldn't be investing our time and money in this project if this were not the case.

In spite of what others may say, you need only look at the Call Book to see that the total number of licensees is continuing to grow. Admittedly, this growth may not be as fast as CB or other parts of the electronics industry, but still, we are growing. This growth could be, and should be, faster, but it is up to us in amateur radio to provide growth. No one else is going to do it for us.

There was, perhaps, a certain period of indecision during the incentive-licensing controversy. This issue has been decided, and the amateur knows exactly where he stands in the future. Home construction ideas and equipment purchases can now be planned with the full assurance that you'll be able to use this gear as intended. The potential newcomer need have no apprehension over what his

future operating privileges will be.

One of our major enemies is considered to be Citizens Band, and yet, it has been a failure. Even Chairman Hyde of the FCC has now suggested that major changes, including an increase in the license fee and a technical examination, should be considered as a means of improving this service. This could well have a very positive effect on amateur radio. The many youngsters who are introduced to radio each year via CB might well be channelled to our novice bands. Both radio services would benefit from this change in policy, as would the individuals involved.

A new outlook is necessary. If we continue to work with old ideas and concepts, we can hardly expect to maintain our traditional spot in the electronics world. We are a branch of one of the fastest moving areas of technology. If you have any doubts, look at the developments of the past few years in solid-state techniques or satellite communications. Amateur radio will have to look and act the part if we are to keep up.

**Ham radio** intends to take a very positive step in the advancement of amateur radio. As a start, this magazine looks years ahead of others because we have taken advantage of new techniques and ideas in technical publishing to bring you something very timely in appearance. Equally as much effort is going into the preparation of editorial material. A lot of work has been done to make the articles easier to read. Ideas have been more clearly organized, words and sentences have been carefully put together with professional techniques designed to make **ham radio** easier and more enjoyable to read!

We still have a lot to do. Our business is communications technology. This goes just as much for the printed word as for the latest integrated circuit. There will be many more new ideas in **ham radio** as the months go by. We think you'll like them.

**Skip Tenney W1NLB**  
Publisher





# A question only serious hams should answer...

by Jack Quinn, W6MJG

How come you are still asking for our obsolete book? The one called "The Care and Feeding of Power Tetrodes." Look, we've already mailed out over 100,000 copies of the thing. It's just got to be in the hands of every amateur who ever went on the air. Don't get me wrong, I'm happy you find it useful. But now you should be asking for our *NEW* book, "The Care and Feeding of Power Grid Tubes."

It so happens that right now on my desk is a pile of these new books. They're really pretty interesting. You see, one of the fellows on our staff—Bob Sutherland, W6UOV—took it upon himself to incorporate the answers to over 400 questions asked of us in a year's time. In fact, he has spent just about every spare moment away from his shack, preparing this new pocket-size book. I couldn't believe that it has almost 200 pages. Bob said he just got carried away. He has expanded the original book, which we published back in '46, so that in its new form it covers all types of power grid tubes in RF and AF

service. Even has graphs and things like that.

Now you're probably wondering, where can I get it? Thought you'd never ask. Right this minute there is another pile of these books at your nearest Eimac/Varian distributor, or your favorite technical bookstore. Figuring all the time we've spent in getting them ready for you, they're really a bargain at \$3.95 each. If it's inconvenient to get to the distributor or the bookstore, write me, and I'll send your request along to the book retailer.

*Jack Quinn*  
*Division Marketing Manager*



Division of Varian  
San Carlos, California 94070

# Order Waters fine ham gear *direct*



## DUMMY LOAD/WATTMETERS

An effective means of measuring and peaking RF power into a dummy load. Four calibrated scales permit accurate readings of RF watts. Protective warning light.

### MODEL 334A

1000 watts.  
2 to 230 MHz ..... \$135.

### MODEL 374

1500 watts.  
2 to 30 MHz ..... \$135.



## PROTAX™ ANTENNA SWITCHES

Unique coaxial selector switches that automatically ground entire antenna system when station is not in use. Handle 1000 watts; complete with hardware.

### MODEL 375 SP6T

Rear Axial Connectors ..... \$13.95

### MODEL 376 SP5T

Side Radial Connectors ..... \$12.50

### MODEL 380 SPDT

Rear Axial Connectors ..... \$12.45

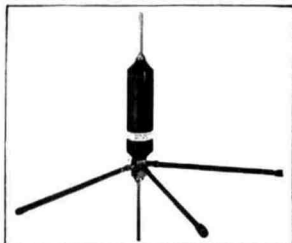

## MOBILE BAND-ADDER®

Add 10, 15 and 20 meters to any standard mobile antenna with 40 or 75 meter coil. Pre-tuned for full coverage on each band. Will carry 500 watts PEP . . . lightweight and installs in seconds.

### MODEL 370-3

..... \$19.95

## AUTOMATCH ANTENNA

Rugged — efficient. (Mast, stainless steel tip and 75 meter coil. Complete)

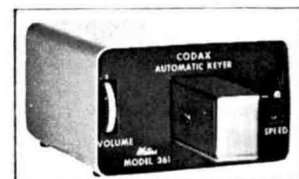

## CODAX KEYSER

Automatic spacing and timing from 5 to 50 WPM . . . built-in double-paddle key adjusts to any fist. Solid state with sealed "Reed" relay . . . keyed audio output at microphone level allows use of VOX circuit on either sideband. Self-powered — operates with any rig.

MODEL 361 ..... \$92.50  
(Less 1.35 volt batteries)



## COUPLER/PHONE PATCH

The ultimate in phone patches providing effortless, positive VOX operation. Also connects tape recorder for both IN and OUT. Available with or without built-in Compreamp which may be used independent of patch.

### MODEL 3001

(Without Compreamp) ..... \$53.00

### MODEL 3002

(With Compreamp) ..... \$72.50



## COMPREAMP

Add definite "talk power" to your signal with Compreamp! Self-powered and solid state, it is easily installed in the mike line of either fixed or mobile station. Great for the added punch when QRM and band conditions are tough.

MODEL 359 ..... \$27.95

## COAXIAL FILTERS (2 & 6 meters)



Double-tuned, resonant cavity band-pass filters for both 2 and 6 meter transmitters and receivers. Installed in 52 ohm antenna lines, the filter assures an outgoing signal free of spurious frequencies that cause interference problems. High level, out-of-band signals are rejected ahead of the receiver front end. Needs no tuning . . . insertion loss held to 1.5 db maximum.

Model 373-2 (2 meters) \$29.50

Model 373-6 (6 meters) \$32.50



## ATTENUATOR

Gives stepped attenuation to 225 MHz from 0 to 61 DB in 1 DB steps. 50 ohms.

### MODEL 371-1

(UHF Connectors) ..... \$29.95

### MODEL 371-2

(BNC Connectors) ..... \$32.50

### MODEL 371-3

(N Connectors) ..... \$38.95



## USE THIS CONVENIENT ORDER FORM

Waters Manufacturing, Inc., is a member of Electronics Industries Association.

...from *Waters*

**Now! Measures RF to a full 2000 watts**

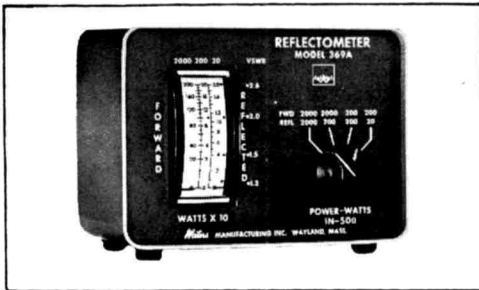

## 369A REFLECTOMETER

Operating 2000 watts PEP? Get WATERS new 369A Reflectometer. You can measure your forward RF output to full legal limit on every transmission AND simultaneously read reflected power. The unique double meter provides a 10:1 increase in sensitivity ensuring accurate readings of low reflected power values. Exclusive "Protective Gap" prevents damage to the coupler in the transmission line. Use your Reflectometer with Waters 384 Dummy Load for either a through-line Wattmeter or a Dummy Load Wattmeter. Reflectometer is compact, portable, easily installed in shack or car. Complete with directional coupler, UHF to BNC adapters and connecting cable.

**\$127.50**

or ...



**order from the exclusive Waters Distributor nearest your QTH**

The complete Waters line is always in stock at all of these exclusive Waters distributors.

**AMATEUR ELECTRONIC SUPPLY**  
Milwaukee, Wisconsin 53216

**AMRAD SUPPLY, Inc.**  
San Francisco, California 94121

**ARROW ELECTRONICS, Inc.**  
Farmingdale, Long Island, N.Y. 11735  
Norwalk, Connecticut 06850  
Totowa, New Jersey 07512  
Mineola, New York 11501  
New York, N. Y. 10007

**ELECTRONICS CENTER, Inc.**  
Dallas, Texas 75204

**ELECTRONIC DISTRIBUTORS, Inc.**  
Wheaton, Maryland 20902

**HARRISON RADIO CORPORATION**  
Jamaica, Long Island, N.Y. 11435  
New York, N.Y. 10007  
Farmingdale, Long Island, N.Y. 11735

**HENRY RADIO, Inc.**  
Butler, Missouri 64730  
Anaheim, California 92801  
Los Angeles, Calif. 90064

**STERLING ELECTRONIC SUPPLY**  
New Orleans, Louisiana 70112

**WORLD RADIO LABORATORIES**  
3415 West Broadway  
Council Bluffs, Iowa 51501

**This order form may be sent direct to the factory or to your nearest Waters Distributor.**

**WATERS MANUFACTURING, Inc., Wayland, Mass. 01778**

**Dept. H-4**

Send Model @ each \$  
Send Model @ each \$

Total Order (Mass. Deliveries Include Tax) Check/Money Order Enclosed \$

NAME CALL

ADDRESS

CITY STATE ZIP



## homebrew 5-band ssb exciter

Here's  
an all-band sideband  
exciter that's simple,  
straight-forward,  
inexpensive and  
easy to  
build.

Fred Randall K1UKX, RFD 2, Blackstone Street, Uxbridge, Massachusetts 01569

Many opinions, both pro and con, have been expressed in regards to homebrew equipment. It is not my intent either to promote or discourage building equipment. I believe the only valid reason for a ham to build his station equipment is his own sincere desire.

Many of those who profess a desire to build their own ssb gear claim it is difficult or impossible because:

1. It is so complex that it takes an engineer to build it.
2. It is difficult to get parts; nobody stocks them, and they are too expensive.
3. A well equipped machine shop is necessary for the mechanical work.
4. Homebrew equipment looks shoddy or makeshift and is, usually, much larger and more bulky than commercial equipment.
5. No time.

The exciter shown on these pages is my answer to those who use any of the standard excuses. It was built in its entirety on a hamshack workbench, using common hand tools and readily available, inexpensive parts. I can appreciate the time problem since I get home at 1:30 AM—this is when I can steal an hour or so to work on my little projects.

Building equipment is no bed of roses, and the subsequent debugging would try the patience of a saint. However, when the work is done and the bugs are exterminated, the satisfaction more than compensates for the barked knuckles, frayed nerves and gallons of coffee and midnight oil.

## circuit description

A block diagram of the homebrew 5-band ssb exciter is shown in **fig. 1**. In this circuit a 6CW4 crystal oscillator generates a signal at either 453.5 or 456.5 kHz, depending upon which sideband is desired. This signal is applied to a germanium-diode ring modulator. One half of a 12AX7A is used as the speech amplifier. The other half is connected as a cathode follower to present the proper low-impedance audio signal to the ring modulator. The output of the modulator is a dsb suppressed carrier signal, which is transformer-coupled to the mechanical filter. The filter passes the chosen sideband and, for all practical purposes, eliminates the unwanted one.

A 455-kHz i-f amplifier follows the filter; the output of this amplifier is fed to a 12AT7

**fig. 1.** Block diagram of the homebrew five-band ssb exciter with the bandswitch set to 20 meters. The components shown by the dotted lines may be added to provide six-meter capability if so desired, although the circuitry is not described here.

balanced mixer. The signal from the VFO, a Colpitts oscillator using a 6BA6, is also applied to this mixer. The VFO tunes from 3955 kHz to 4455 kHz—a 500-kHz tuning range. This signal is nulled out in the balanced mixer.

The output of the 12AT7 mixer is applied to another i-f amplifier. The input and output of this amplifier are gang-tuned by additional sections of the VFO tuning capacitor to the **difference** frequency (3500 to 4000 kHz). This tracking amplifier further eliminates the possibility of any VFO signal appearing at the output.

A 6AU8A is used as a converter to heterodyne the 80-meter signal up to other bands. For 80-meter operation, the plate circuit of the 6AU8A pentode section is provided with a load resistor and operates as a low-gain amplifier. For 40- through 10-meter operation a signal from a 6CB6 crystal oscillator is applied to the triode section, and the plate circuit of the pentode section is tuned to the

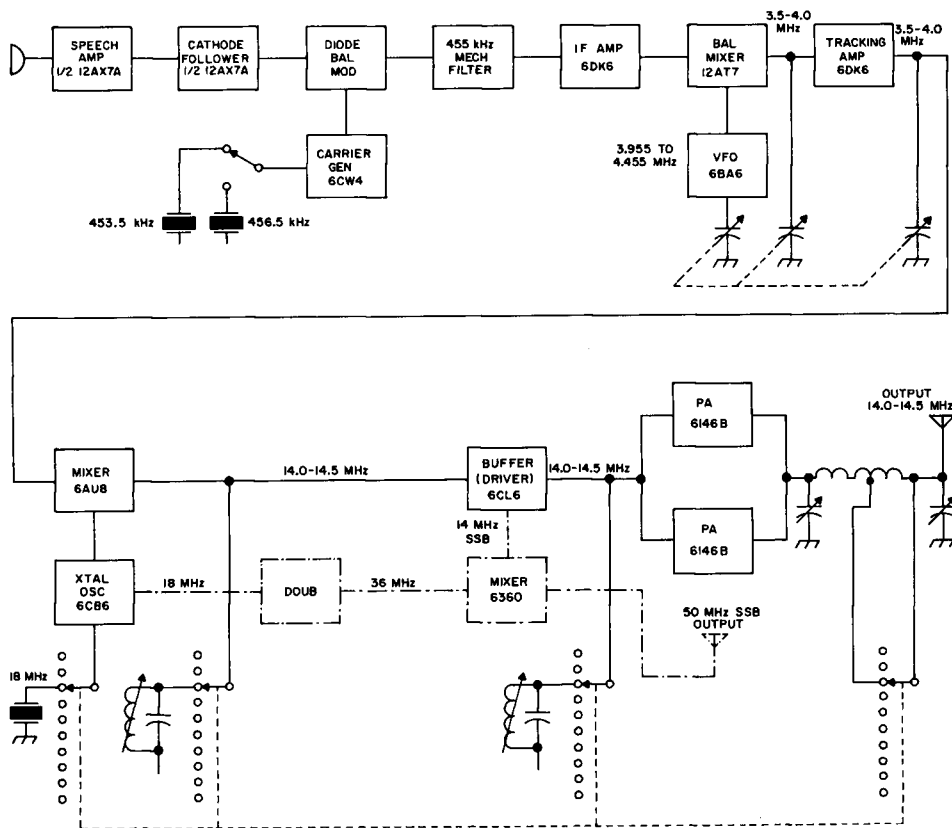

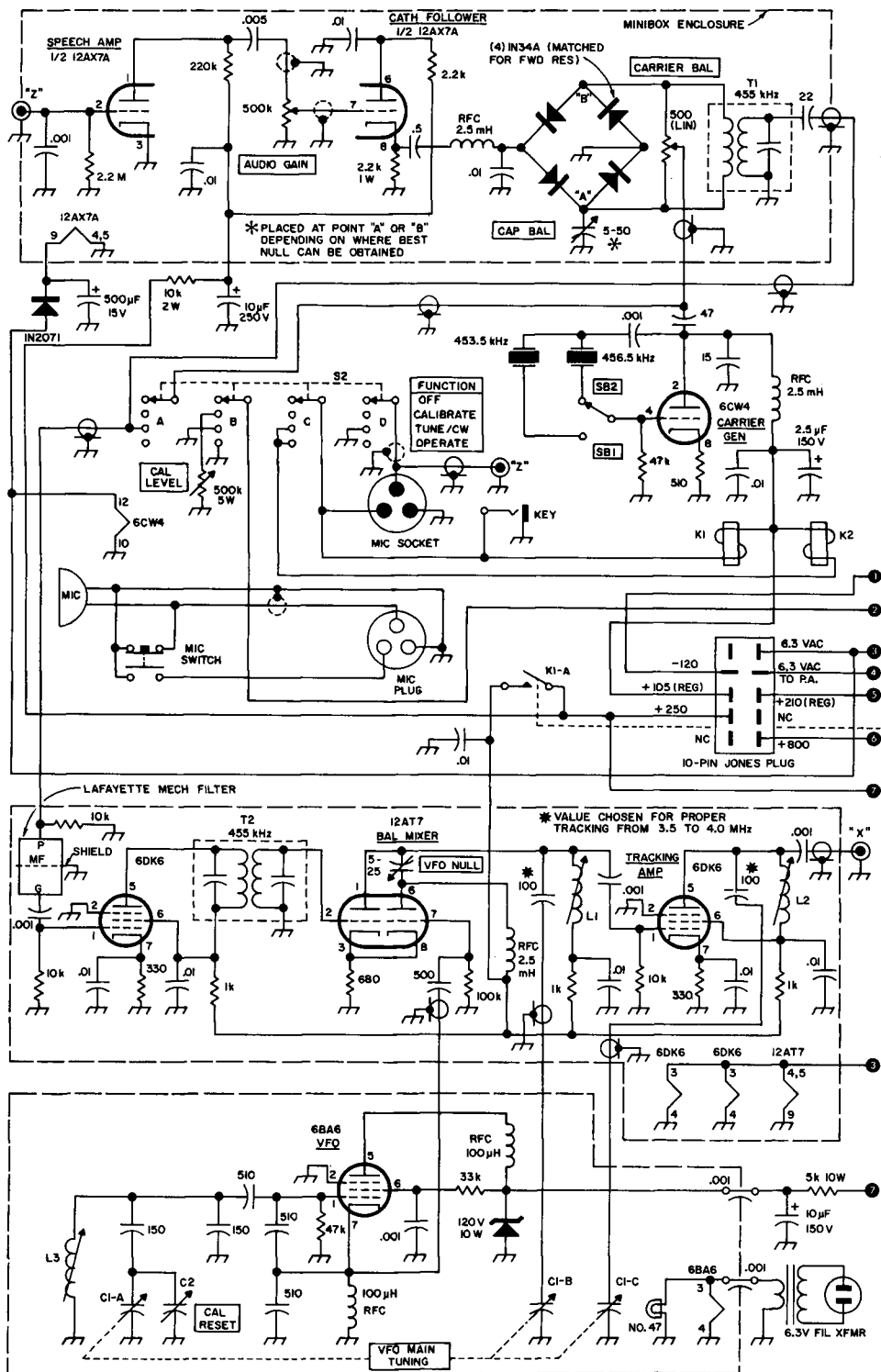

fig. 2. Schematic diagram of the low-cost five-band ssb exciter. Switch S2 (function) is in the tune-CW position,



desired band. No direct coupling is used between the tube sections; sufficient mixing action is provided by inter-electrode capacity and by having the cathodes strapped together. The 6AU8A mixer is followed by a conventional class-A buffer amplifier and a bandswitched final using class-AB<sub>1</sub> 6146B's.

The rule I use in anything I build is to use what I have available, rather than to try and locate and purchase what I don't have on hand.

This general rule was followed in building this exciter. The crystals and mechanical filter had to be purchased of course, but they were available "off the shelf" at Lafayette.\* The 455-kHz i-f cans are available at any radio store or they may be removed from an old broadcast radio.

All of the circuits used in this exciter were obtained from various sources and adapted for use with components I had. It may be possible to further optimize the circuits, but the values I used work very well.

The carrier crystals and heterodyning crystals as well as the VFO frequency match

**table 1**

| band | tuning direction | sideband SB-1 | selection SB-2 |
|------|------------------|---------------|----------------|
| 3.5  | normal           | upper         | lower          |
| 7.0  | reversed         | lower         | upper          |
| 14.0 | reversed         | lower         | upper          |
| 21.0 | reversed         | lower         | upper          |
| 28.0 | normal           | upper         | lower          |
| 28.5 | normal           | upper         | lower          |
| 29.1 | normal           | upper         | lower          |

heterodyning is used to obtain the various bands, the tuning direction, as well as the selected sideband, changes with the band in use. This is a small inconvenience which you soon become accustomed to, and allows simpler and less expensive construction. The chart in **table 1** shows the tuning direction and normal sideband in use on the 80-through 10-meter amateur bands.

### chassis and cabinet

A good starting point is the cabinet. I used an LMB\* CO-1; price \$20.00. One point

\* Available from Newark Electronics Corporation, 500 North Pulaski, Chicago, Illinois 60624. Catalog number 91F1192, \$19.95 plus postage.

**fig. 3. Construction of the chassis and front panel. The chassis is cut down from a Bud AC419 to 12 1/4" deep. When the 3/8" lip is formed around the front, the overall depth is twelve inches. A four-inch slot, 1/4" wide, is cut out along the front of the chassis for dial clearance and lead routing. The completed chassis is mounted to the 1/8"-thick stiffener plate (sub-panel with countersunk screws.**

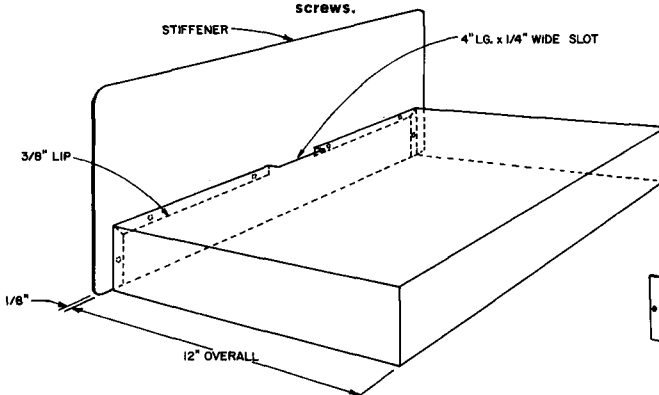

**fig. 4. Method used for making shielded compartments for the bandswitch using two 1 1/2" x 2" x 4" miniboxes. The circuits are built into each compartment, tested, and then assembled into a complete unit.**

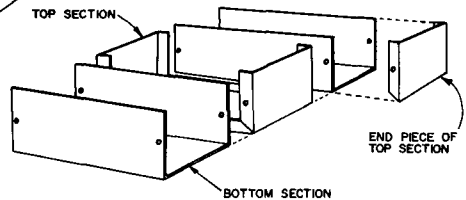

the Lafayette HA-350 Receiver in use at K1UKX. For this reason, transceive operation is quite practical, with only slight modifications to the receiver.

Because both summing and differencing

\* Lafayette Radio Electronics, 111 Jericho Turnpike, Syosset, L. I., New York 11791. Order replacement part for HA-350 receiver, \$12.95.

which bears mentioning at this time is that when you use a decent appearing foundation for construction projects, it goes a long way toward encouraging the builder to complete them.

The dial bezel is cut from 1/4-inch thick stock. I used plexiglass, but wood would be a perfectly acceptable substitute. After cutting



and filing it to shape, I sprayed it with machine-gray Krylon. While still tacky, the bezel was given a "dusting" coat of the same paint from about three feet away. This gives an attractive sandblast matte finish which blends well with the cabinet. The dial windows are cut from 1/8-inch plexiglass and cemented to the rear of the bezel. A hairline is scribed in the center of the left-hand window.

The chassis consists of a front sub-panel cut from rack panel material and a commercial chassis, Bud AC419. The chassis is cut to size with a hacksaw or nibbling tool, bent to shape and bolted to the front panel using recessed-head screws. The use of a double panel permits a face plate completely free of unsightly screw heads. It also provides the rigidity necessary for mechanical stability of the VFO. The VFO compartment side plates are also cut from rack-panel material. These plates are bolted to the chassis and front panel after construction of the VFO. The rear panel of the cabinet is cut away to provide access to the chassis apron.

The front panel lettering is done with Walsco decals. After they are in place, the panel is given a coat of clear Krylon. A light dusting coat is then applied to return the panel to a semi-gloss finish. This seals the

fig. 5. Front finish panel for the five-band SSB transmitter. A full-scale template is available from K1UKX for 25c to cover postage and handling. Lips are formed at the top and bottom of panel as shown in fig. 6.

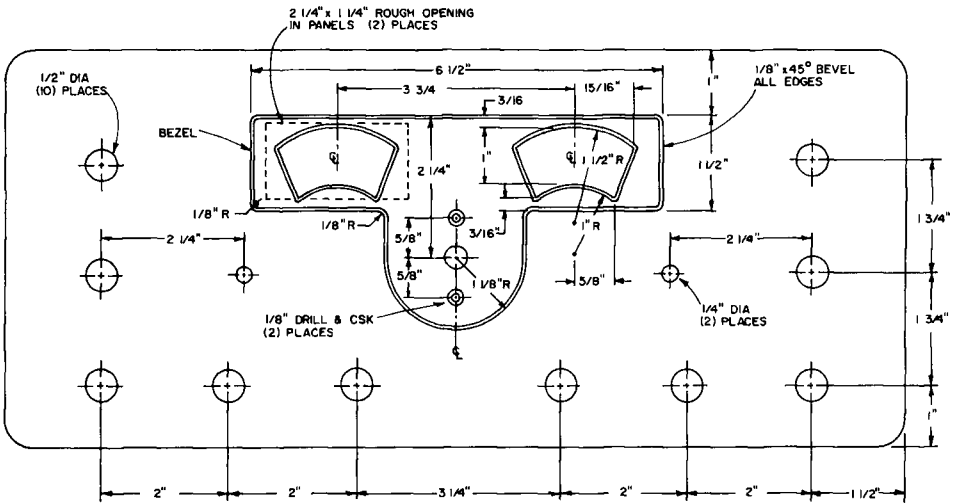

**table 2. Parts list for exciter**

- C1 -- ARC-5 receiver tuning capacitor
- C2 -- ARC-5 receiver antenna-trim capacitor
- L1, L2, L3--40 turns #26 enameled on 1/2" slug-tuned form.
- L4--12 turns #22 enameled on 3/8" slug-tuned form.
- L5 -- 10 turns #22 enameled on 3/8" slug-tuned form.
- L6, L9 -- 8 turns #22 enameled on 3/8" slug-tuned form.
- L7 -- 22 turns #22 enameled on 3/8" slug-tuned form.
- L8, L13 -- 15 turns #22 enameled on 3/8" slug-tuned form.
- L10 -- 6 turns #22 enameled on 3/8" slug-tuned form.
- L11 -- 65 turns #30 enameled on 3/8" slug-tuned form.
- L12 -- 18 turns #22 enameled on 3/8" slug-tuned form.
- L14 -- 9 turns #22 enameled on 3/8" slug-tuned form.
- L15 -- 4 turns #22 enameled on 3/8" slug-tuned form.
- L16, L17 -- Pi-Dux 820-D-10 with 4 turns removed from the 10 turns-per-inch end; replaced with 5 turns B&W 3006 mounted at right angles as shown in photograph. Tapped at the junction of the Pi-Dux unit and B&W 3006 and at 34, 41, and 44 turns from the coupling-capacitor end.
- K1, K2 -- 4PDT, 15 kilohms, 110 Vdc, (Allied Control T163X-25).
- PC1, PC2 -- 6 turns 1-16" thick, 1/8" wide copper strip wound around 39-ohm, 2-watt resistors.
- S1, S2 -- Built up from Centralab index section and wafers.
- T1 -- 455 kHz i-f transformer (Workman TF11 although others will work) with primary winding and tuning capacitor removed and replaced with 50 turns #32 enameled, scramble wound next to secondary.
- T2 -- 455 kHz i-f transformer (Workman TF11).

decals and completely hides their edges, giving the appearance of silk-screen lettering.

**speech amplifier and balanced modulator**

The speech-amplifier and balanced-modulator circuitry is built as a unit in a small mini-

box. The balance potentiometer is located in front of the minibox with an extension shaft through to the front panel. The audio-gain control is located on a bracket attached to the minibox by the nut that retains the balance pot. Wiring to the gain control is accomplished with small shielded cable; power and signal leads come out through a hole in the bottom. It might be well to mention here that this method of construction not only provides excellent shielding, it makes for more pleasant building—you don't have to horse a big chassis all over the bench during construction. It also allows individual testing of sub-assemblies, a procedure which I highly recommend because it's much easier than aligning the whole exciter at one whack.

### carrier generator

The 6CW4 carrier generator tube is located in the small space between the minibox and the front panel on the left side of the chassis as shown in **fig. 6**.

### filter-mixer i-f amplifier

These stages are built into another minibox. Small sheet-metal protrusions provide room for the use of full-size 1/2-inch tuned coils on the input and output circuits of the tracking amplifier. All the leads from the box,

**Below-chassis view of the five-band ssb exciter. The VFO tube and carrier generator crystals are in the upper left center; the bandswitch is to the right.**

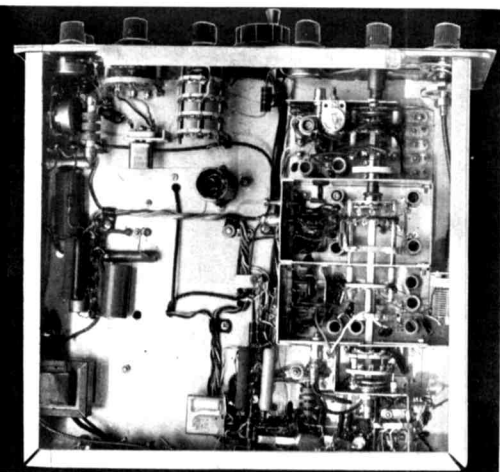

as well as the coil leads to the ARC-5 tuning capacitor, are shielded. Access to the balanced-mixer nulling capacitor is available from the bottom of the main chassis through a small access hole. Proper tracking is established by juggling capacitor values in series with the ARC-5 variable capacitor sections. I trimmed some plates from my unit, but by proper choice of series capacitors, this should be unnecessary.

**Inside the five-band ssb exciter. Power amplifier compartment to the lower left.**

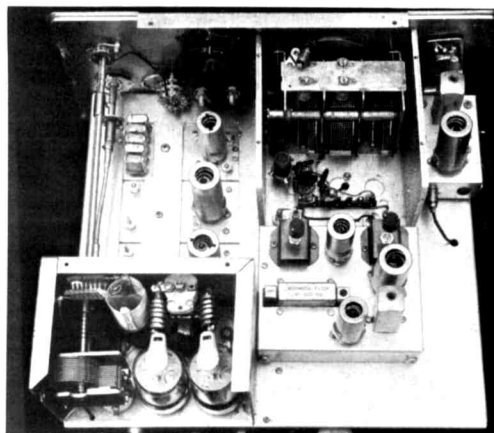

### variable frequency oscillator

The VFO is a standard Colpitts oscillator using a 6BA6 tube. The tube is located under the chassis and all circuitry associated with the VFO is contained in a shielded compartment. The 6BA6 is provided with a separate filament transformer and the heater runs as long as the exciter is plugged in. A number 47 bulb, which is used to keep the VFO compartment warm, is also connected. These provisions make warm-up drift negligible and no temperature-compensation circuitry is required.

Plate and filament voltage to the VFO is run through feed-through capacitors from under the chassis. The VFO plate voltage is zener regulated at 120 volts. A small 10-pF variable capacitor is connected in parallel with the main tuning capacitor and provides about  $\pm 10$  kHz variation for tuning-dial calibration. This capacitor was removed from the same ARC-5 receiver that yielded the main-tuning capacitor. It is placed between the tuning capacitor and the face plate; this is a tight

squeeze but it fits after careful positioning.

The center section of the main-tuning capacitor is used for the VFO. The remaining sections are used to tune the tracking amplifier. Note that a capacitor is placed in series with the main-tuning capacitor—this limits the tuning range to 500 kHz, and makes the dial calibration extremely linear.

### bandswitching details

The bandswitch is built up from Centralab wafer and index sections. These are coupled together with fixed and flexible couplings. The crystal oscillator, mixer and buffer are constructed separately in minibox sections and, after testing, assembled into a three-section unit and installed in the chassis. The

fig. 6. Side view of the chassis showing the position of the mechanical filter compartment on the left-hand side of the chassis. Note the lips at the top and bottom of the front finish panel.

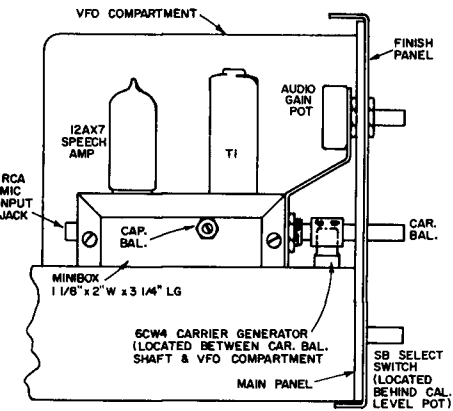

main chassis is cut out slightly to provide clearance for tubes, slugs, and crystals as shown in the below-chassis photo.

Plate and filament voltages are supplied to the individual sections via feed-through capacitors; phono jacks are provided for input and output signals. This facilitates removal of the assembly if service is required.

The small size of the final amplifier compartment prevents the use of a three-section output capacitor, so fixed capacitors are switched in on the 80-, 40-, and 20-meter bands.

In the 50.0, 50.5, and 51.1 position of the

bandswitch, all ten-meter stages at 28.0, 28.5, and 29.1 MHz are turned on except the final amplifier. The output of the 6CL6 driver stage is taken from an RCA jack on top of the chassis and applied to an external six-meter transverter. The transverter is built in an identical cabinet which it shares with the power supply that runs the exciter.

It would be feasible, in the 14-MHz position, to run a doubler stage after the 18-MHz oscillator used to heterodyne the ssb signal to 14 MHz. The resultant 36-MHz signal could be mixed with the 14 MHz ssb signal already being generated to provide an output on 50 MHz. With a 6360 mixer, the entire set-up could be contained within the exciter itself. This would give 80- through 6-meter coverage with a tuning range of 50.0 to 50.5 MHz on six. It would be asking too much to run the 6146B finals on six meters, but the output from the 6360 could be used to drive an external amplifier or used barefoot at about 5 watts PEP. This circuitry is not included in the schematic, but is shown in the block diagram.

fig. 7. Construction of the driving mechanism for the ARC-5 tuning capacitor. The dial scale is mounted to the original dial retaining nut with a 4-40 screw.

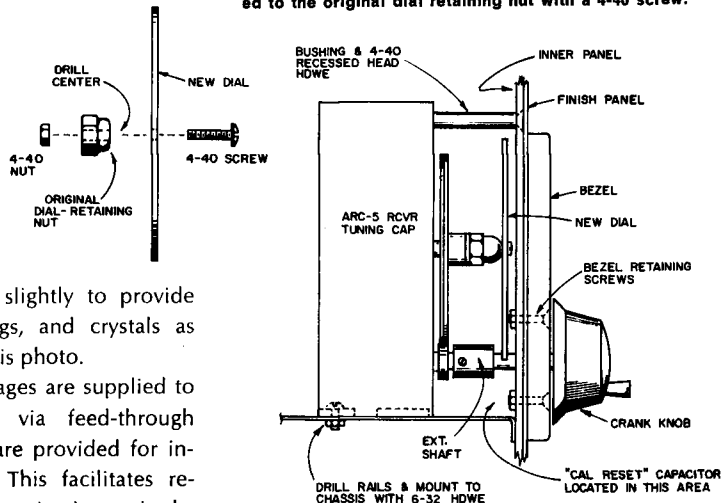

### final amplifier

The final amplifier is a conventional neutralized circuit using a pi-network output. The two 6146B tubes are connected in parallel and are provided with regulated grid bias and

Live Better Electronically With

# LAFAYETTE RADIO ELECTRONICS

## NEW! 6-METER SOLID-STATE MOBILE TRANSCEIVER

with **BUILT-IN VFO**

5 WATT DC INPUT

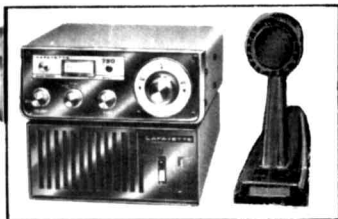

Only **119<sup>95</sup>**

Stock No. 99-2605WX (50-52 mHz)  
No Money Down

**MOBILE**  
As Is

**FIXED STATION**  
With Optional AC Supply

**PORTABLE**  
With Optional DC Pack

- Sensitivity Better than 1  $\mu$ v for 10 db. S/N
- Tuneable Receiver, Xtal/VFO Transmitter
- 18 Transistors, 8 Diodes, 2 Zener Diodes

- $\pm$ 200 KC Vernier Receiver Tuning
- Supplied with Cables, Brackets, and PTT. Mike
- For 12 Volt Negative Ground Only

- Built-in 2.5 Watt Public Address Facilities

## POWERFUL 120 WATT MOBILE LINEAR AMPLIFIER

- No External Switching Required
- Completely Self-Contained 12 Volt Toroid Power Supply
- Tuneable RF Circuitry
- Built-In Metering Circuit For Exciter Or Linear RF Power Output
- For 12 Volt Negative Ground

Only **139<sup>95</sup>**  
NO MONEY DOWN

2 Meter 120 Watt P.E.P. Model #40-0108WX (Illustrated) \$139.95  
6-15 Meter 100 Watt P.E.P. Model #40-0106WX \$79.95



Made In U.S.A.

## OUR BEST SELLING 6 AND 10 METER TRANSCEIVERS



99-2579WX HA-460 For 50-52 mHz  
99-2575WX HA-410 For 28.0-29.7 mHz

with **BUILT-IN VFO**

- Dual Conversion With Crystal Controlled 2nd Converter
- Built-In 117 VAC And 12 VDC Supplies
- Sensitive Tuned Nuistor Front End
- 20 Watt DC Input -2E26 Final
- Illuminated "S" and P. F. Meter

Only **149<sup>95</sup>**

No Money Down

Completely Wired

**OVER 500 EXCITING PAGES**

WRITE: P. O. Box 18, Syosset, L.I.,  
LAFAYETTE RADIO ELECTRONICS CORP., Dept. 51-8

# FREE!

1968  
CATALOG  
680

# HEY! HOW ABOUT THAT

## S.W.R. BRIDGE

- MODEL SWB-2
- READS FORWARD AND REFLECTED POWER SIMULTANEOUSLY
- "EASY READ" METERS
- USE FOR REFERENCE POWER METER
- DUAL 100-MICROAMP METER MOVEMENTS
- LOW INSERTION LOSS
- SIZE-5"X2"X2"

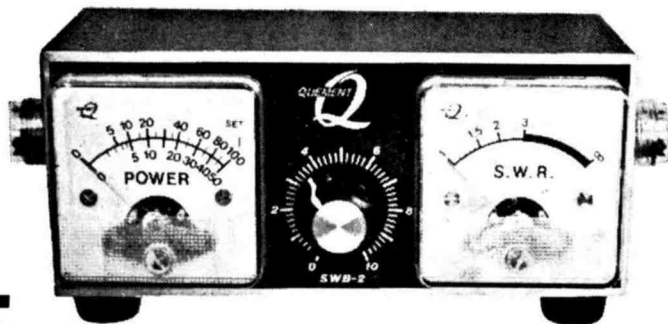

# \$15.95

ALLOW \$1.00 FOR  
PACKING & SHIPPING  
CALIFORNIA RESIDENTS  
INCLUDE SALES TAX

THE BEST  
VALUE WE  
HAVE  
EVER  
OFFERED!

MAY BE LEFT  
IN LINE, UP  
TO 2000 WATTS.

GOOD THROUGH  
2 METERS

SINCE 1933

FAST SERVICE

Phone CY 4-0464

# QUEUMENT ELECTRONICS

1000 SOUTH BASCOM AVENUE

SAN JOSE, CALIFORNIA

"Northern California's Most Complete Ham Store"

95128

screen voltage. The cathode pins on the tube sockets are bent inward toward the center and strapped together with a tinned-copper strip. Flat copper strips are also used for the plate parasitic suppressors, and many of the connections in the bandswitch assembly make use of the same material.

## control functions

Most of the control functions are either self-explanatory or discussed elsewhere in the text. A few functions, perhaps, require further explanation.

The **calibrate** position of the function switch permits the operator to "talk" himself on frequency, or, if desired, the carrier may be inserted and a conventional zero beat can be accomplished. In either case, the push-to-talk switch (or key) must be depressed to energize the transmitter. The **calibrate level** control sets the spotting signal to a comfortable listening level.

In the **tune-CW** position of the function switch, the balanced modulator is bypassed to provide a CW carrier when the key or push-to-talk switch is depressed. Full break-

in CW permits maximum operating convenience. This is accomplished through the use of high-speed relays.

The meter is switched to read either final cathode current or output. Antenna change-over and receiver muting are built in, as is push to talk. Any power supply that will provide the indicated voltages at the power-plug terminals may be used.

No tuning or alignment instructions are given here since it is assumed that anyone with the necessary skills to build an exciter such as this one will be thoroughly familiar with the proper techniques.

It is not expected that anyone will build an exact copy of this transmitter. However, some of the construction methods and circuits used here should be of interest to other appliance operators who prefer, as I do, to build their own appliances.

## References

1. ARRL, **Single Sideband for the Radio Amateur**, American Radio Relay League, Newington, Connecticut, Third Edition, 1962.
2. D. Stoner, **New Sideband Handbook**, Cowan Publishing, New York, 1962.



Construction of the FET converter for 50 MHz. Input circuits are to the left.

## fet converters

for  
**50, 144, 220**  
and  
**432 mhz**

Looking for  
good cross-mod and  
low-noise performance  
above 50 MHz?

Try these VHF FET  
converters  
designed  
by  
W6AJF

Frank C. Jones W6AJF/AF6AJF, 850 Donner Avenue, Sonoma, California 95476

Several new field effect transistors are available to radio amateurs at very attractive prices from 90 cents to \$1.10 apiece. These FET's are similar to vacuum tubes, with characteristic curves similar to pentodes, but with input-to-output feedback capacitance more like a VHF triode. When FET's are used in neutralized circuits, they provide fairly good gain values at radio frequencies and compare favorably or surpass tubes at VHF. These devices have less cross-talk or intermodulation problems than ordinary bipolar transistors and usually less than vacuum tubes. In addition, noise figures are normally lower than with tubes costing several times as much. Lower noise figures mean better weak-signal reception. At lower radio frequencies, FET's can be used without neutralization by mismatching load impedances; this is frequently done with bipolar transistor circuits. However, at VHF and UHF, neutralization of the feed-through capacitance is required for best noise figure and stage gain.

### 50-MHz converter

The use of grounded-gate circuits eliminates the need for neutralization, but with some deterioration of noise figure. The stage gain is roughly half as much as with gate input, grounded-source circuits with neutralization. Grounded-gate FET circuits are com-

parable to grounded-grid tube circuits but have lower noise-figures when the proper types of FET's are chosen. A good example is the 50-MHz converter shown in **fig. 1**. Here two stages of grounded-gate FET's provide enough gain at 50 MHz to permit the use of an FET mixer stage with its marvelous low cross-modulation characteristics.

FET mixers require several times as much oscillator injection power as a bipolar transistor mixer and only provide a fraction as much conversion gain as a good bipolar mixer stage. However, the low cross-modulation characteristic is extremely desirable in the 50-MHz band where signals are extremely strong during band openings, and an FET mixer is a must in a good converter. The problem is to

**The 50-MHz FET converter.**

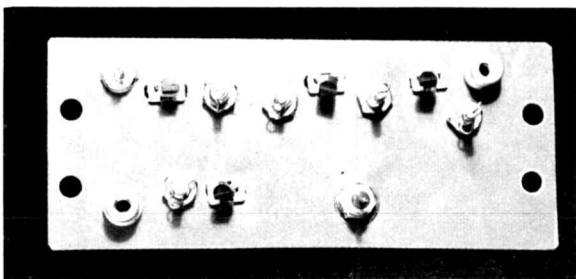

**fig. 1. Six-meter FET converter with a noise figure of 1.5 dB. L1 is seven turns #20 on a 3/8" slug-tuned form, spaced 3/8" long, tapped at 2 1/2 turns. L2, L3, L4, and L5 consist of 15 turns #24 enameled on a 3/8" slug-tuned form; secondary of L2 and L5 is two turns.**

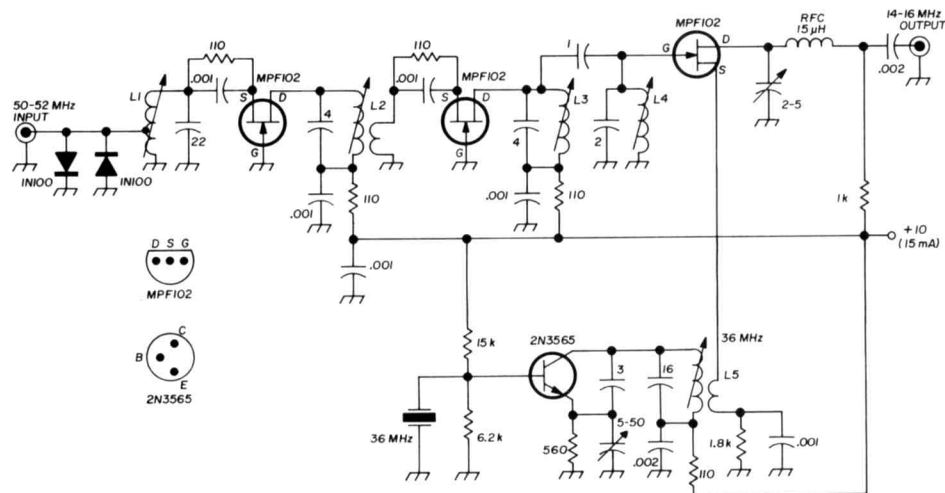

provide enough rf gain ahead of the mixer stage to give a low overall noise figure, but not enough to overload the mixer when strong signals are present. The source bias resistors in **fig. 1** are values which resulted in the best noise figure with MPF-102 FET's when used with a regulated 10-volt power supply. A supply of 12 or 15 volts would require an increase in bias resistance to keep the drain-to-source current at 4 to 5 mA per stage.

At my location there are no active 50-MHz stations nearby, so quite a bit of rf amplification can be used ahead of the mixer. In other locations, less gain might be desirable, and larger source bias resistors may be used in the two rf stages. In such cases, the bias resistor and bypass capacitor in each stage should be in the ground-return lead of the secondary winding of the tuned circuits. The bias resistor of each rf stage is connected to a single 500- or 100-ohm variable resistor so that the overall rf gain for a minimum mixer cross-modulation can be readily adjusted for optimum results.

The two 1N100 diodes connected back-to-back across the input jack of all of these converters is a standard procedure at W6AJF to protect the input transistor when operated in conjunction with high-powered transmitters. These diodes can produce cross-modulation if a neighborhood transmitter is being operated on a frequency near the desired signal reception spot. When this

happens, a 6- to 20-dB pad in the antenna lead will cure the problem but will result in pretty poor reception of anything but fairly strong local or skip signals.

Any nearby transmitter which can produce cross-modulation in the front-end diodes, will overload the mixer stage, even with little or no rf stage gain, so a pad in the coaxial line or a null position of the beam antenna is about the only solution.

In **fig. 1**, four 50-MHz slug-tuned circuits provide a fairly flat frequency response over a 2- to 3-MHz bandwidth. The output impedance-matching circuit will cover as much as 4-MHz bandwidth. This circuit is an L-matching circuit resonant at 15- or 16-MHz to transform the mixer impedance of several thousand ohms down to the 50- or 75-ohm coaxial line to the communications receiver. Mixer injection from the oscillator is introduced at the source electrode. The coupling coil to the oscillator should be adjusted in number of turns and coil coupling to provide about  $\frac{1}{2}$  volt of oscillator energy at the mixer source terminal. A diode rf voltmeter is useful at this point. If an rf voltmeter is not available, oscillator injection can be adjusted to a level which gives a little less than maximum mixer gain from a signal source. This is because the modulation characteristics are not obtained at maximum mixer conversion gain.

The crystal oscillator circuit can be used with any overtone crystals in the range of 20- to 40-MHz by changing the collector circuit L-C values so the tank circuit tunes to the desired overtone frequency. The adjustable 50-pF emitter bypass capacitor is useful in obtaining maximum oscillator output. The base resistors should be values which will

**The 144-MHz FET converter; noise figure below 2.5 dB.**



hold the collector current of the 2N3565 to about 2 or 3 mA. These Fairchild 2N3565 plastic-cased bipolar transistors have high-gain values and give excellent outputs in overtone-oscillator and frequency-doubler or -tripler circuits. Other types of bipolar transistors having an  $h_{fe}$  over 100 and an  $f_t$  of at least 200 MHz could be used as an oscillator.

The TIS34 FET's from Texas Instruments can be used in place of Motorola MPF-102's (or -104's) by changing the source bias resistor in the two rf stages. Values of 330 to 510 ohms are required to keep the drain current to 5 mA or less with TIS34's. Any of the FET's

**Inside the two-meter converter. The input coil and small neutralizing coil are to the left; the oscillator, lower right.**

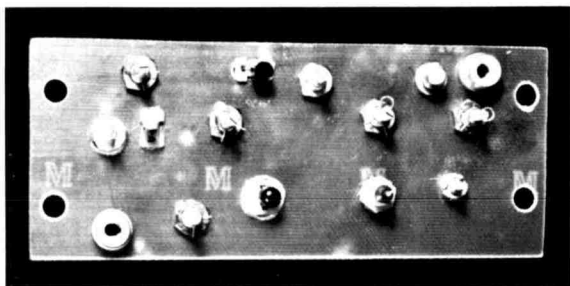

used in these converters will function as mixers up to about 200 MHz with 1000- to 1800-ohm source bias resistors and drain currents of 1 to 2 mA with oscillator injection.

The 50-MHz converter shown here has a noise figure of about 1.5 dB in the 50- to 52-MHz range. If the unit is stagger-tuned to obtain 4-MHz bandwidth, the gain drops, and the average noise-figure is around 2.5 dB. This is low enough for nearly all "average-noise" locations, but the 1.5 dB noise figure is better for forward-scatter signal reception and helps on weak voice signals even in average locations. Man-made noise in some locations can wipe out the performance of any low-noise front end and cause much operator frustration.

### 144-MHz converter

At 144-MHz, the MPF-102 doesn't give as low a noise figure as the slightly more expensive TIS34 or Union Carbide UC734. The



latter seems to be a little better than the TIS34 and was used in the first stage of the 144-MHz converter with the feedback capacitance neutralized out with a tuned coil connected from gate to drain through a dc blocking capacitor. The neutralizing coil should be mounted on the gate side of the interstage shield and enough copper plating scraped away from the coil-mounting area to eliminate grounding the tuning slug and mounting hardware. This slug-tuned coil has to have enough inductance to resonate at 145 MHz with the gate-to-drain capacitance of the transistor plus the miscellaneous shunt capacitances across the coil. A good starting point is 20 turns of number 30 enameled wire on a 3/16-inch diameter slug-tuned form. More or less turns may be needed with the layout and FET used in order to put its tuning

meant that an FET mixer, with its attendant low-conversion gain, was highly desirable to reduce cross-modulation from mountain-top relay stations and other strong signal sources. This means that two rf stages are generally desirable in order to give good weak-signal reception. A minimum of four tuned circuits plus a large cavity-tuned antenna filter is needed to put image signals down -80 dB or more. The converter shown here has -60 dB image suppression by itself for the 14- to 18-MHz i-f output range. The noise figure measured from 1.8 to 2.5 dB over the 144- to 148-MHz range. This results in very good weak-signal reception with a large antenna and fairly low-noise location.

The second stage of the 144-MHz converter is a grounded-base circuit using either a TIS34 or UC734. Even a MPF-102 does a

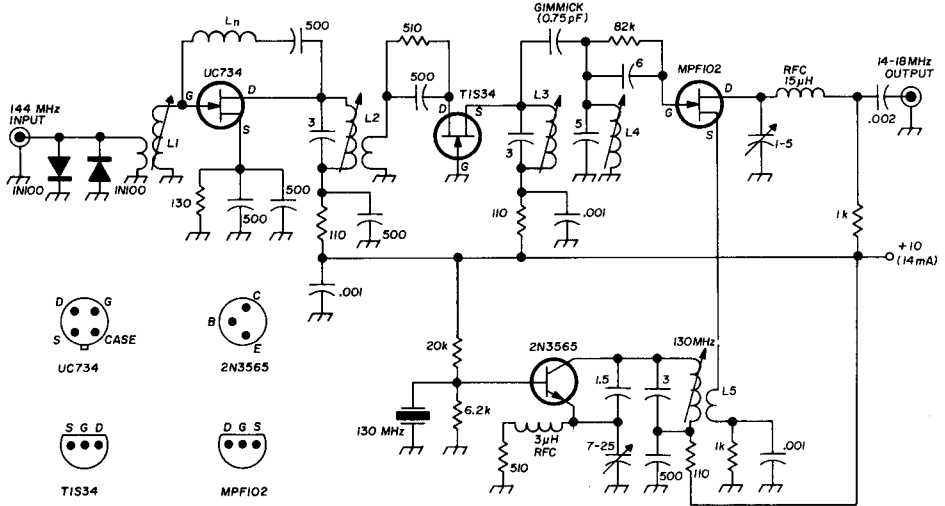

fig. 2. Low-noise FET converter for 144 MHz. L1, L2, L3, L4, and L5 consist of five turns #20 spaced 5/16" on 5/16" diameter slug-tuned form; primary of L1 and secondary of L5 are one turn; secondary of L2 is two turns. The gimmick capacitor is a short length of hookup wire twisted together as shown in the photo. The neutralizing inductor  $L_n$  consists of 30 turns #30 enameled closewound on a 3/16" diameter slug-tuned form.

range within the 144 MHz band. Careful adjustment of coils  $L_1$ ,  $L_2$ , and  $L_n$  is needed to arrive at good neutralization and lowest noise figure in the two-meter band.

The popularity of the two-meter band, with its great number of stations in nearly all areas,

good job at 144 MHz, but each of these FET's requires a different socket connection, so it's difficult to make comparisons. When this converter was first built, a few TIS34's were occasionally available, and MPF-102's and selected MPF-104's were readily available. The UC734 units weren't out yet, so the Union Carbide 2N4416 was used. The 2N4416 costs several times as much, but is quite similar to the UC734 FET's.\* Later tests with several UC734's indicated the same gain

The UC734 is essentially the same as the 2N4416 except for a slight relaxation in  $g_m$ ,  $I_{GSS}$  and  $I_{DSS}$  specifications.

and noise figure results as with the 2N4416's. The socket connections are identical, and in testing either type, some adjustment of the neutralizing coil was needed to eliminate rf oscillation in the first stage.

The overtone crystal oscillator in **fig. 2** functions quite well with 130-MHz seventh-overtone crystals at 1 to 2 mA collector current. If 43.33-MHz crystals are used, the base-bias resistors must be changed to get about 3 mA collector current to drive the FET mixer. These mixers require from 3 to 5 times as much oscillator injection voltage as a bipolar mixer, and if there isn't enough, the conversion gain rapidly drops off.

### 220-MHz converter

Except for the mixer and oscillator stages, this converter is somewhat similar to the one built for the 144-MHz band. The mounting

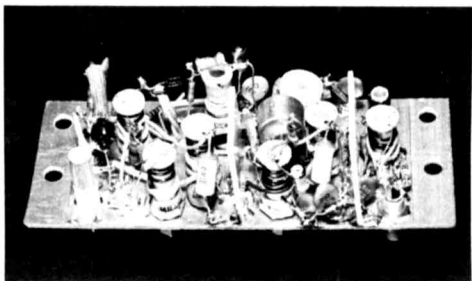

plate is five inches long by two inches wide, copper plated on the bottom side; this is the same as the 50- and 144-MHz converters. As can be seen in the photograph, to get all the circuitry into a 5 x 2-inch space results in a pretty cluttered layout. A surplus low-frequency "rolling-pin" overtone crystal was available; the oscillator triples to 69 MHz and a low-capacitance, fast-computer diode, a 1N914, is used to triple again to reach 206 MHz for oscillator injection into the mixer stage.

The output from the 1N914 was too low for an FET mixer, and since this band isn't ordinarily bothered with strong signals at my location, a bipolar 2N3478 mixer was connected as shown in **fig. 3**. The resultant gain of the whole converter is very high, and in some locations the rf stage or stages may need a gain-control potentiometer in series with the source-bias resistors. TIS34's, if

available, or UC734's can be used in both rf stages.

The TIS34 has higher feedback capacitance and would require less turns on the neutralizing coil ( $L_n$ ). It would also require different socket connections and, perhaps, a 200-ohm bias resistor. Again, the bias resistors depend upon the power-supply voltage. The first FET should be run at approximately 5 mA drain current, and the second stage at a little less.

### The 220 MHz converter using MPF-104 FET'S.

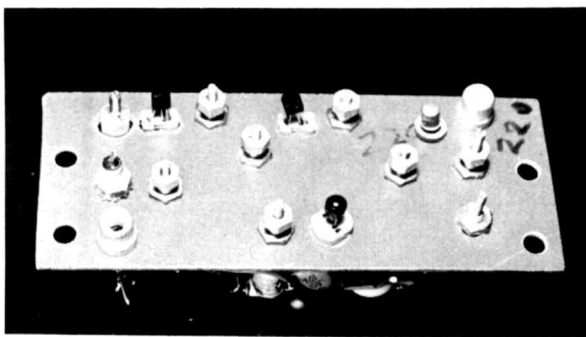

Layout of the 220-MHz converter. Input coil and neutralizing coil to the right; oscillator at top center.

The noise figure of this converter seems to be very good, measuring 2.0 dB at 220 and 222 MHz and 2.5 dB at 224 MHz. The 2N4416 and UC734 FET's are a little better than the TIS34 units I tested. The UC734 could have been used to advantage in the second stage with a change in bias resistor and socket connections, but its higher gain wasn't necessary.

The oscillator injection voltage into the 2N3478 mixer was measured at from 0.1 to 0.2 volts with a diode rf voltmeter as compared to the usual 0.5 volts or more for the FET mixer. If the station location requires an FET mixer because of strong signals from radar or radio stations, the oscillator chain would require a much more expensive diode tripler using a varactor or other highly efficient frequency multiplier. The 69-MHz output of the oscillator would probably have to be set up for maximum rf power output. An



ting up one of these hot 432-MHz neutralized stages.

The final result of all adjustments in the first stage is to prevent rf oscillation, obtain best noise figure and good, but not maximum, gain. With only one rf stage these adjustments would probably also coincide at maximum gain. With two rf stages, oscillations took place several MHz up the band where the antenna-lead impedance became something other than 50-ohms resistive. With this in mind, the input and neutralizing circuits

**FET's on 432 MHz.**  
Two rf stages with copper-strap tank circuits; rf input to the right. The mixer and oscillator circuits are on the left.

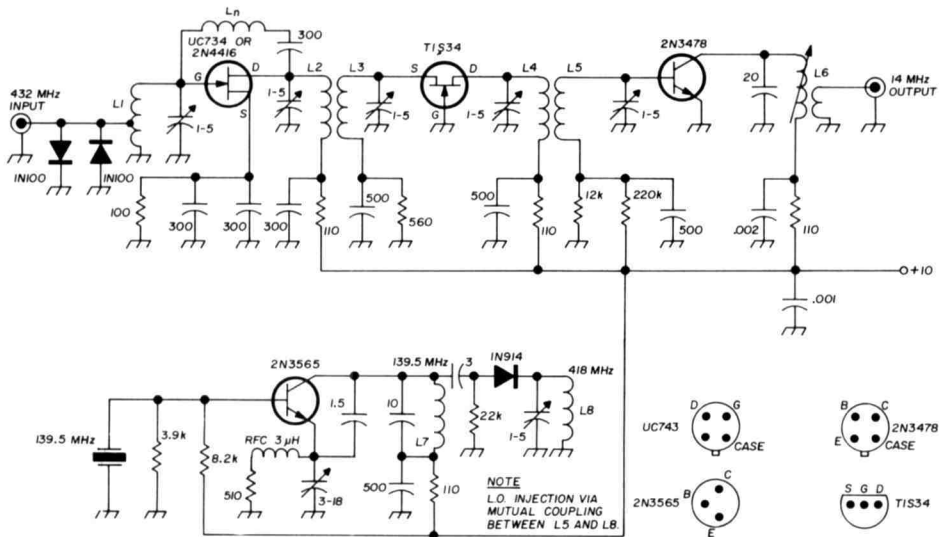
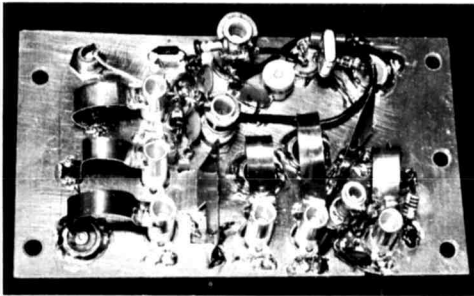

fig. 4. This low-noise converter for 432 MHz exhibits a noise figure of 2.5 dB. L1, L2, L3, L4, L5, and L8 are copper straps approximately  $\frac{1}{4}$ " wide by  $1\frac{1}{4}$ " long. Local-oscillator injection into the mixer is accomplished by mutual coupling between L5 and L8. L6 consists of 28 turns #30 enameled closewound on a  $\frac{1}{8}$ " slug-tuned form with a  $2\frac{1}{2}$  turn secondary. L7 is 3 turns #20 spaced  $\frac{1}{4}$ " long on a  $\frac{5}{16}$ " slug-tuned form.  $L_n$  is 4 turns #20 spaced  $\frac{1}{4}$ " on a  $\frac{3}{16}$ " slug-tuned form.

must be adjusted to knock out this spurious oscillation for smooth operation and best noise figure. The drain circuit was always tuned for maximum gain at 432 MHz.

The following source circuit was detuned slightly and closely coupled to the first stage to help get rid of oscillations when the antenna impedance changes with frequency or weather. The following tuned circuits (three in a row at the end of the converter strip) were tuned for maximum signal response.

The 418-MHz oscillator injection voltage to the mixer was obtained in the simplest way possible—a 139.333-MHz overtone-crystal oscillator and 1N914 tripler. No attempt was made to use an FET mixer at 432-MHz.

One item that I have not mentioned was the use of two disc bypass capacitors from source to ground in the first stage of the neutralized rf amplifiers. This capacitor will normally tend to cool off the first stage for rf oscillation when using socket-mounted transistors. I am not enough of an optimist to believe that a converter can maintain peak performance without changing front-end transistors—hence the sockets!

ham radio

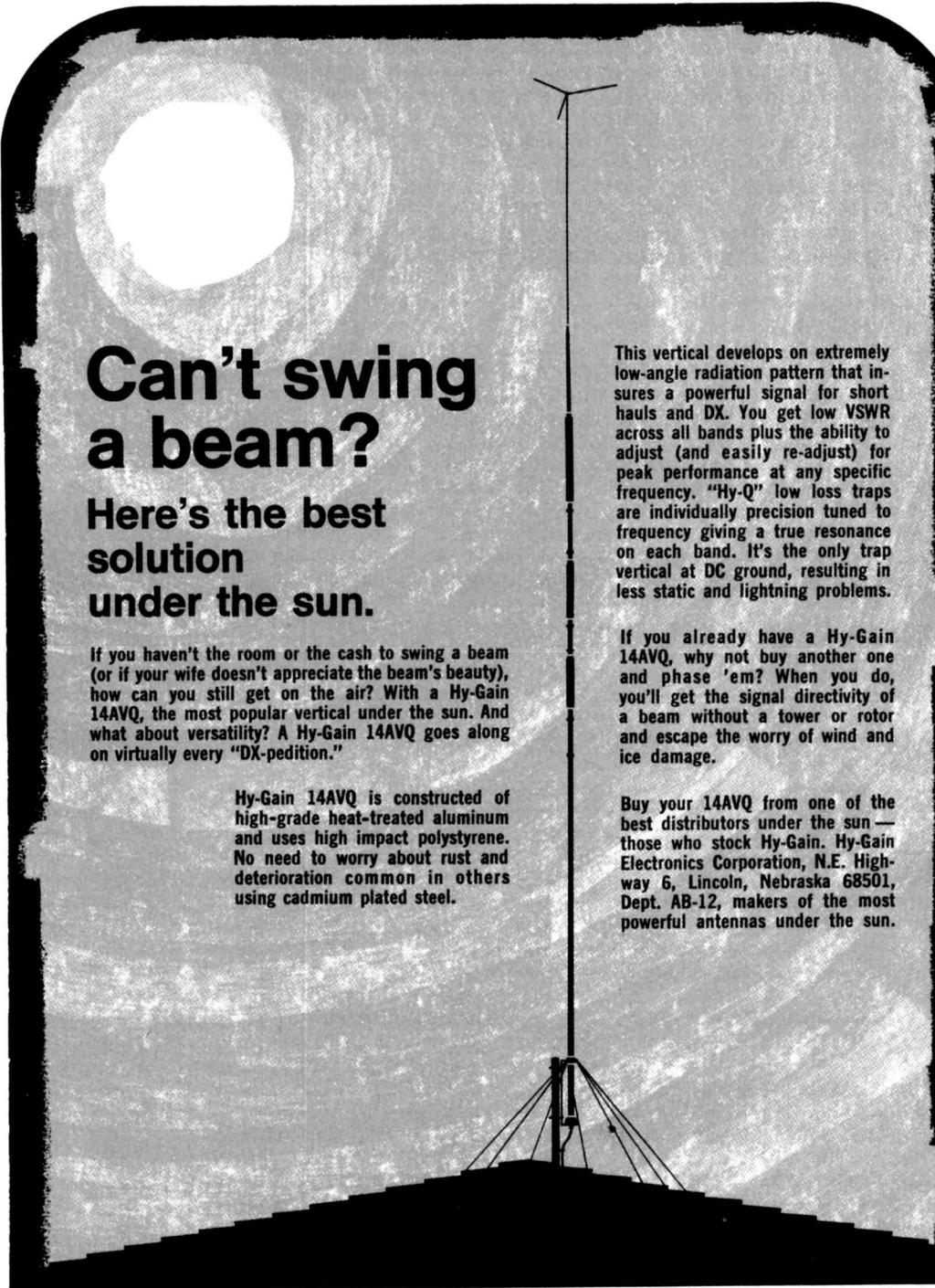

## Can't swing a beam?

Here's the best  
solution  
under the sun.

If you haven't the room or the cash to swing a beam (or if your wife doesn't appreciate the beam's beauty), how can you still get on the air? With a Hy-Gain 14AVQ, the most popular vertical under the sun. And what about versatility? A Hy-Gain 14AVQ goes along on virtually every "DX-pedition."

Hy-Gain 14AVQ is constructed of high-grade heat-treated aluminum and uses high impact polystyrene. No need to worry about rust and deterioration common in others using cadmium plated steel.

This vertical develops an extremely low-angle radiation pattern that insures a powerful signal for short hauls and DX. You get low VSWR across all bands plus the ability to adjust (and easily re-adjust) for peak performance at any specific frequency. "Hy-Q" low loss traps are individually precision tuned to frequency giving a true resonance on each band. It's the only trap vertical at DC ground, resulting in less static and lightning problems.

If you already have a Hy-Gain 14AVQ, why not buy another one and phase 'em? When you do, you'll get the signal directivity of a beam without a tower or rotor and escape the worry of wind and ice damage.

Buy your 14AVQ from one of the best distributors under the sun — those who stock Hy-Gain. Hy-Gain Electronics Corporation, N.E. Highway 6, Lincoln, Nebraska 68501, Dept. AB-12, makers of the most powerful antennas under the sun.

# Hy-Gain 14AVQ

HY-GAIN ANTENNAS, FOR THE MOST POWERFUL SIGNAL UNDER THE SUN

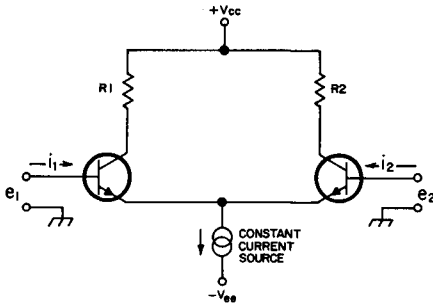

fig. 1. The basic differential-amplifier circuit which is used in most linear integrated circuits. This circuit requires both positive and negative supply voltages.

# IC- regulated power supplies for integrated circuits

These plus and minus power supplies for IC work use a new circuit element—the integrated-circuit voltage regulator

Hank Olson W6GXN, 3780 Starr King Circle, Palo Alto, California 94306

The big push in integrated circuits in the last year or so has been in the linear IC area. With internal fighting between RTL, DTL, ECL and TTL digital types still going on, many IC manufacturers seem content to make **all** these logic families available, and concentrate their new-product efforts on linears. As a result of the "linear-push," prices have dropped to the point where amateurs can become linear IC users.

The linear IC configuration which is the most practical to fabricate is the differential amplifier. A basic amplifier of this type is shown in **fig. 1**. It has become popular because it is versatile and is readily adapted to single-chip construction. Since the resistors and transistors are on the same chip, nearly perfect temperature-tracking is obtained—i.e., things stay balanced! A typical linear IC (operational amplifier) is shown in **fig. 2**; note the differential circuitry. Note also that this amplifier is entirely dc coupled.

It is this dc-coupled, differential-amplifier configuration which dictates that most linear IC's require equal positive and negative power supplies. Two standards seem to be emerging in the field: those requiring plus and minus 6 volts, and those requiring plus and minus 15 volts. The following dual-regulated supplies are presented to simplify testing of larger circuits utilizing these new linear IC's.

## dual-regulated power supplies

Both of the dual-regulated supplies described here use a new linear IC made especially for this service: the National Semi-



A dual IC-regulated power supply which provides plus and minus fifteen volts.

conductor Corporation LM300.\* It sells for \$6.40 in small quantities and is an economy version of an IC regulator (the LM100 costing nearly ten times as much.) As such, it is a real bargain for ham use. The various application notes which describe the use of the LM100 apply to the LM300 within specification limits.<sup>1,2</sup> The supplies are basically the same as those described in reference 1, but use less expensive semiconductors for amateur use.

The first supply is designed for linear IC's which require plus and minus 15 volts. It uses a slightly modified Triad F40X power-transformer to provide two separate 13.4 Vac windings, instead of the 26.8 Vac center-tapped configuration. This modification is very simple—the insulating paper is simply cut to expose the point where the centertap lead is soldered to the two formvar windings. The separated formvar leads are then soldered to new flexible insulated leads and the

\* The name of your local National Semiconductor distributor may be obtained from National Semiconductor Corporation, 2950 San Ysidro Way, Santa Clara, California 95051.

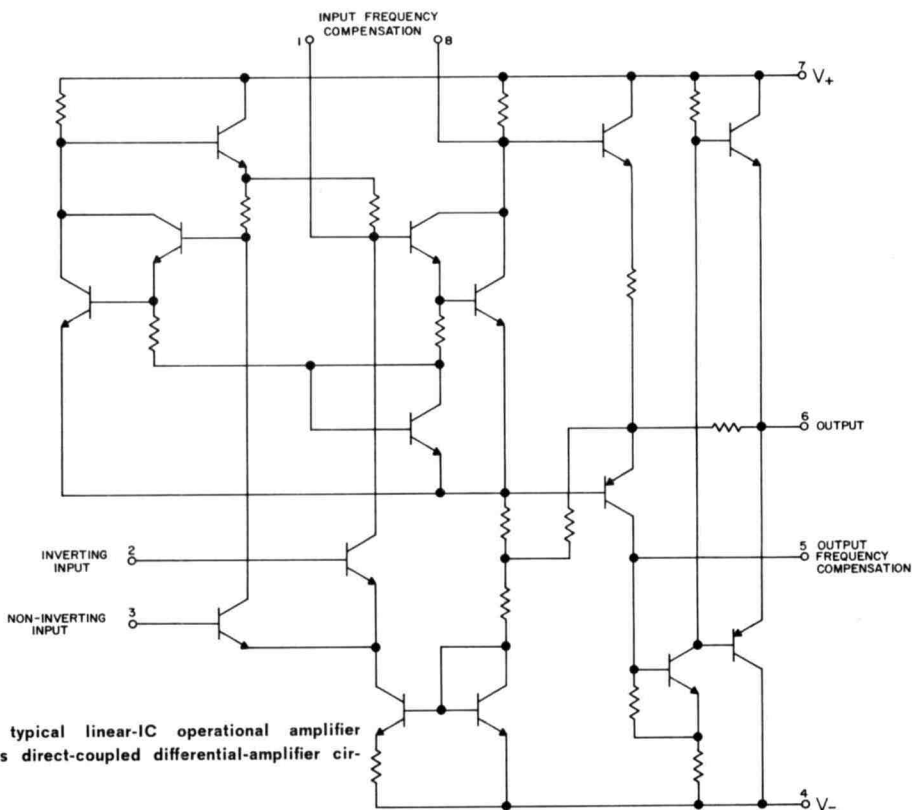

fig. 2. A typical linear-IC operational amplifier which uses direct-coupled differential-amplifier circuitry.

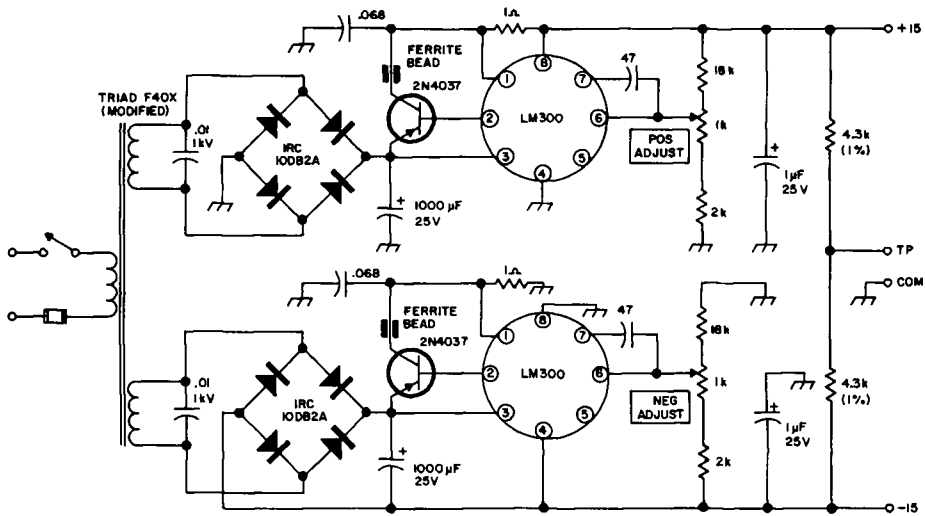
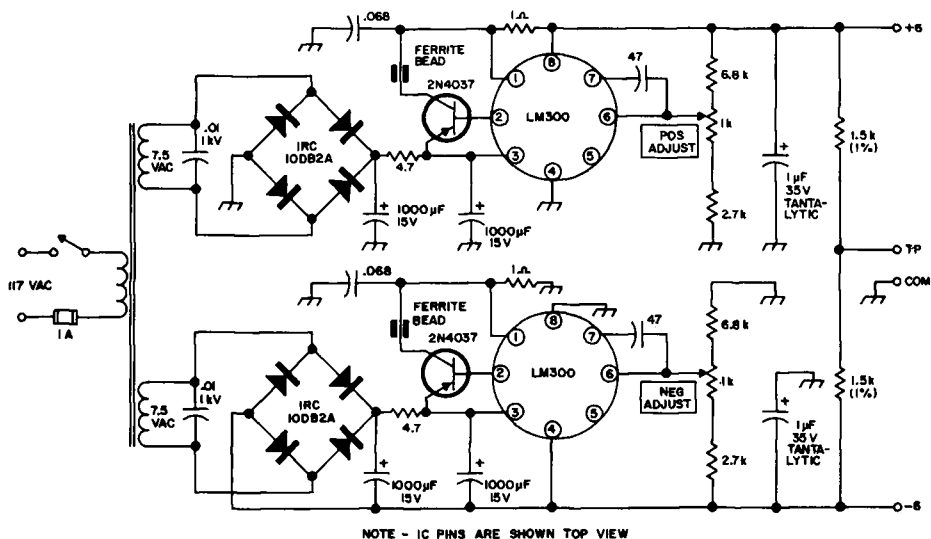

fig. 3. A dual-regulated IC power supply using LM300 voltage regulators which puts out  $\pm 15$  volts. The 2N4037 power transistors are mounted on Wakefield 254S1 insulated heat sinks. The ferrite beads may be purchased from Ami-tron Associates.\*

gouged paper is covered with RTV Silastic for insulation and support. The IRC 10DB2A encapsulated-bridge rectifier could be replaced with a Motorola MDA920-4 or HEP176, or by a Mallory FW200.

The second supply is designed to accommodate those linear IC's that require plus and

fig. 4. Dual regulated supply which provides  $\pm 6$  volts. The 2N4037's are mounted on Wakefield 254S1 heat sinks; the ferrite beads are available from Ami-tron Associates.



minus 6 volts. The transformer for this unit is a dual 7.5 Vac filament type which costs between three and four dollars.

A balance test point (TP in fig. 3 and 4) is provided in both circuits for a quick check of symmetry between the plus and minus output voltages. Two matched resistors (1%) are series-connected to draw a few milliamperes of current between supplies. If the two supplies are providing equal voltages, the TP should be at zero voltage, as measured to ground with a VTVM. The TP is normally connected in operation of the supply.

\* Ami-tron Associates, 12033 Otsego Street, North Hollywood, California 91607.



For those of you who are distrustful of IC's in power-supplies, **fig. 5** represents a plus and minus 15-volt supply using discrete components. Of course, a person who distrusts IC's in the power supply would not likely want a  $\pm 15$ -volt supply to test other IC's, but this discrete circuit dramatically shows how much extra circuitry the LM300's eliminate. A careful cost comparison, using Allied Radio's catalog, will show that there is only a dollar or two difference between the discrete and integrated-circuit supplies.

### construction

Several precautions are necessary in building the supplies shown in **fig. 3** and **4**. The 47-pF capacitor between pins 6 and 7, and the 1- $\mu$ F capacitor between pins 4 and 8 of the LM300 should be placed as close to the IC as possible. One of the regulators developed some parasitic oscillations at higher currents; the 0.068 $\mu$ F capacitor from pin 1 to chassis-ground and the ferrite bead on the 2N4037 collector lead corrected the problem. Even though this trouble only showed up in the

**fig. 5. Dual-regulated 15-volt supply which uses all discrete components. There is little price difference between this model and the one which uses an integrated-circuit voltage regulator. The 2N3053 transistors are equipped with clip-on heat dissipators.**

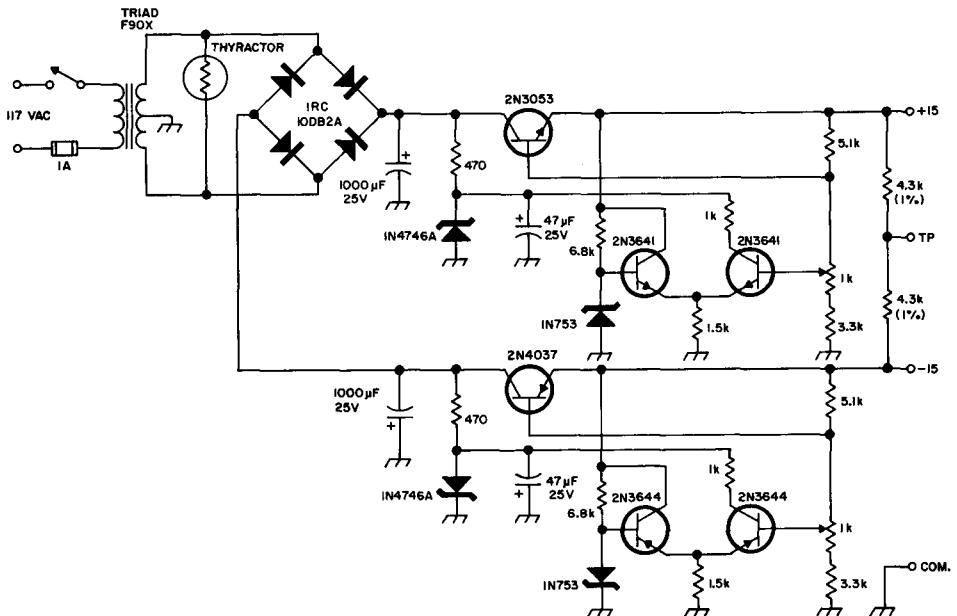

unit when it was spread out on the bench, these measures were included in both circuits.

### operation

Both IC-type supplies are capable of at least 100 mA output with less than 10 mV drop in voltage. The regulator sections are not the limitations in these circuits; they will operate to 200 mA with 0.1% regulation. The rectifier-filter system is the limiting factor. The circuit shown in **fig. 5** can also be used to 100 mA; the output voltage drops about 100 mV at 100 mA and 2.5 volts at 200 mA.

References 3 and 4 are recommended for general information on linear IC's. These inexpensive paper-bound books show applications for, and precautions to be taken in, using linear integrated circuits.

### ham radio

#### bibliography

1. Widlar, R., "A Versatile, Monolithic Voltage Regulator," National Semiconductor Corporation Application Note AN-1, February 1967.
2. Widlar, R., "Designing Switching Regulators," National Semiconductor Corporation Application Note AN-2, April 1967.
3. R.C.A., "Integrated Circuit Fundamentals," R.C.A. Technical Series, IC-40, July 1966.
4. Giles, J., "Fairchild Linear Integrated Circuits Applications Handbook," Fairchild Semiconductor Corporation, 1967.

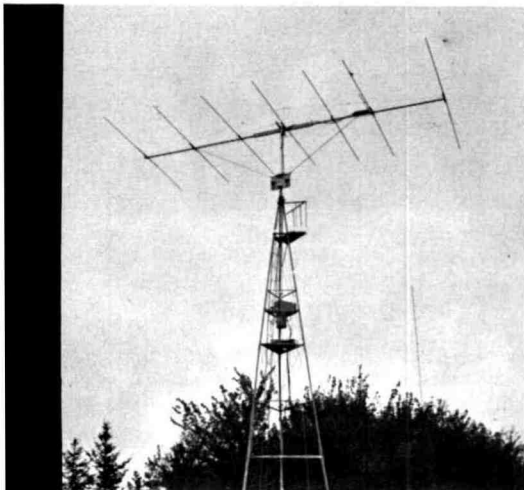

The completed seven-element, remotely-tuned, ten-meter beam mounted on top of the 50-foot tower. The two support struts below the boom are made from dural tubing and give the long boom additional support.

a  
**big beam**  
for  
**ten meters**

Here's a  
beam that's designed for  
performance—seven  
elements on a  
thirty-  
foot  
boom

■ With the 10-meter band returning to life, and the rapidly improving DX conditions, thousands of hams are turning to thoughts of antennas. The usual controversies are developing over which type is best and which to erect. At my station, both beams and quads have been used with excellent results on ten. The last effort, a two-element quad, proved to be especially good.

However, the building urge came along just after the last series of DX contests, and I felt that the next project should be a new yagi. This beam would be somewhat larger than previous efforts, with emphasis on front-to-back ratio and ease of tuning. The last effort along these lines was a four-element affair which performed well enough to indicate that a few more elements would be even better. The antenna which eventually took shape is described here and is an excellent project, even for a beginner. Construction is straightforward, and although the antenna is large, it may be scaled down to a size you consider appropriate for your station.

George Cousins VE1TG, RR 2, Lower Sackville, Nova Scotia

## design

This beam is a seven-element yagi with a 30-foot boom. This configuration requires a lot of attention to mechanical as well as electrical details—particularly if you live in a bad-weather location. However, the results obtained with this beam are well worth the effort put into its construction. An interesting feature, and one which I have never seen described before, is the remotely-controlled gamma match which can be precisely operated from the hamshack. This permits accurate gamma-match tuning over the entire ten-meter band. Anyone who has ever attempted to tune a beam from the top of a tower can appreciate the convenience of this device.

**Center support for the boom shown mounted on the mast.**

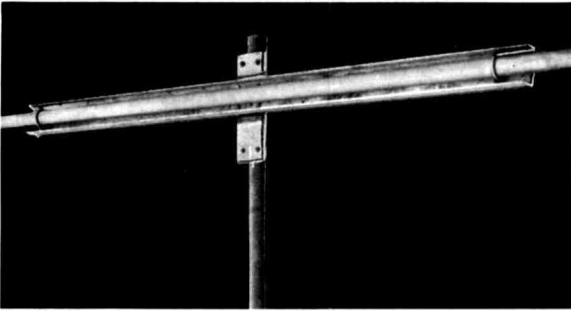

You should start this project with pencil and paper rather than with drill and metal. First, decide upon the number of elements. You should consider cost, availability of materials, time, experience, and probably most important of all, the mechanical characteristics of the tower and rotator. Even with light-weight materials, this antenna presents a lot of stress on its supporting structure. By using standard formulas, you can work out the dimensions (in feet) of the beam elements for any chosen operating frequency:

$$\text{Driven element} = \frac{473}{\text{Frequency (MHz)}}$$

$$\text{Directors} = \frac{450}{\text{Frequency (MHz)}}$$

$$\text{Reflector} = \frac{501}{\text{Frequency (MHz)}}$$

Although the number of elements makes the bandwidth narrower than a smaller beam, this is not a disadvantage, since few operators actually cover the entire ten-meter band. In the case of the phone DX'er, for example, the beam would be optimized around 28.4 to 28.6 MHz, while the CW man would prefer a design centered on 28.1 MHz or so.

## construction

A look at **fig. 1** will show the general arrangement of elements. The 30-foot boom permits spacing to the operator's preference. For wider bandwidth and less critical adjustment, the elements should be spaced out to about seven feet. However, this will only allow room for five elements. In my case, I was interested in maximum front-to-back ratio rather than gain, so the element spacings I used were selected to achieve this purpose. This is indicated by the wide spacing from driven element to reflector, and narrow spacing from driven element to first director.

**Two methods of fastening the elements to the boom mounts—standard pipe clamps and muffler clamps.**

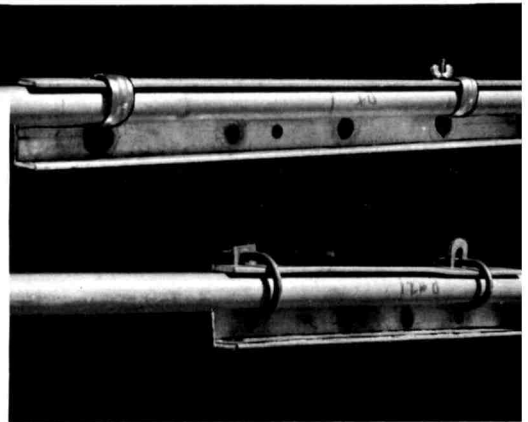

With this spacing, I was able to add two more elements, sharpening the beam pattern and increasing the front-to-back ratio.

Despite the obvious advantages of so many elements, there is a matching problem because the radiation resistance falls to a low value. This not only makes it more difficult to match the feedline to the driven element, it means that the operating bandwidth for a

given SWR is quite narrow. The remote gamma-match tuning was incorporated to overcome this problem.

### the elements

In selecting materials for the beam, keep the important factors of strength and weight in mind. Aluminum tubing is the logical choice—6061-T6 alloy. This tubing comes in standard 12- to 13-foot lengths. A full length should be used for the center section of each element. The extension pieces on each end of the element are made from smaller diameter tubing which telescopes into the larger. I used  $\frac{7}{8}$ -inch diameter, 0.058 wall, for the larger tubing, and  $\frac{3}{4}$ -inch diameter for the smaller. The  $\frac{3}{4}$ -inch tubing can have very thin walls because little strength is required in such short lengths. The 0.058-inch wall of the larger tubing results in a snug fit when the sections are telescoped together.

The ends of the large tubing are split with a hacksaw for about one inch. Then the short extension pieces are inserted, and the overall length of each element is adjusted to the proper dimensions. A stainless-steel hose clamp is used to clamp the large center tubing over the smaller end sections. This prevents them from slipping in or out. It's also a good idea to paint the joints with aluminum paint

and wrap them with waterproof tape. Each element can be made up in the basement or garage and set aside until they're put on the boom.

Several methods can be used to mount the elements on the boom. I prefer small pieces of aluminum channel which are fastened to the boom with standard automobile muffler clamps. The element is laid in the trough of the channel and fastened securely in place with pipe clamps or small U- or J-bolts. Since aluminum channel is expensive unless you can find some in a junkyard, small sections of angle iron or aluminum will do just as well. Just remember to give special attention to rust-proofing anything that isn't aluminum.

Detailed view of the boom support and boom-to-mast mounting plate.

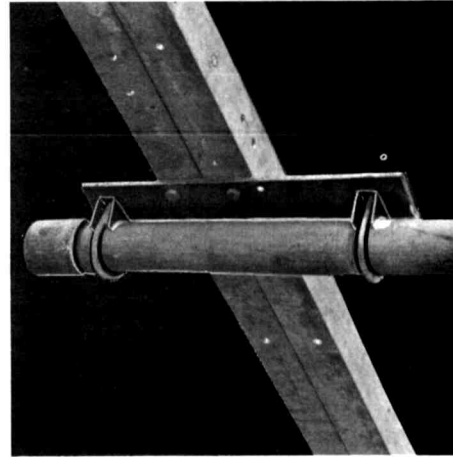
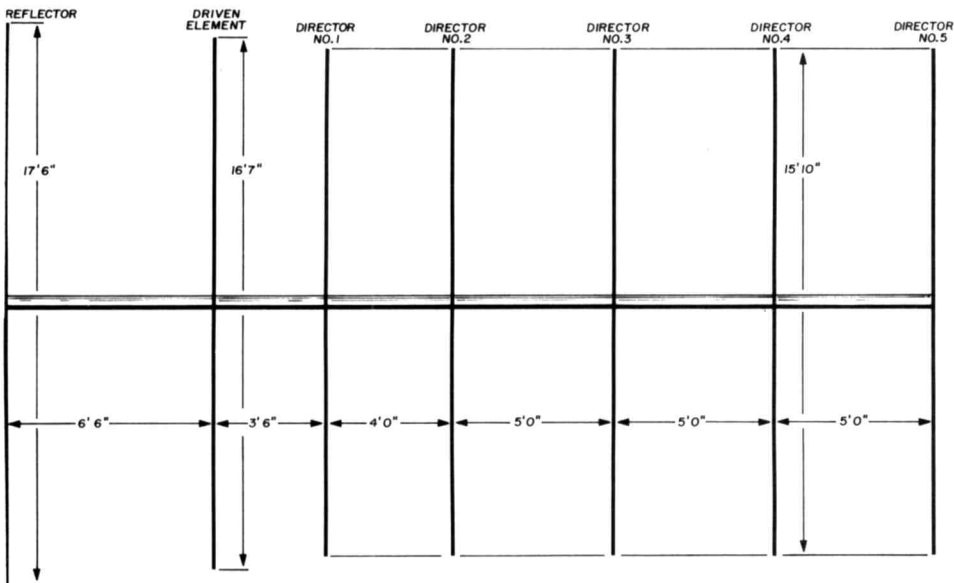

fig. 1. Overall dimensions of the seven-element beam designed for a center frequency of 28.5 MHz.



Muffler clamps may still be used to fasten the angle to the boom, and the element can be hung on the side of the angle.

### the boom

The boom is made from a 30-foot length of aluminum irrigation pipe. This pipe should have a diameter of two inches or more. I found the two-inch material fine for a four-element beam on a 20-foot boom (an earlier project), but too flexible for this long beam. However, since it had the advantage of light weight, I strengthened it and found it completely satisfactory.

First of all, I used a four-foot support section made from two pieces of aluminum

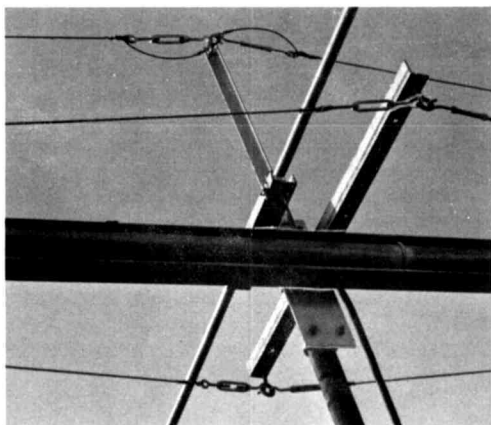

Closeup of the center of the boom showing the bracing wires, struts and turnbuckles.

angle at the center of the boom. The boom is fastened to this mount with three clamps, and the boom-to-mast mount is made from 1/4-inch thick iron plate fastened to the angle with bolts. Two more muffler clamps are used to fasten the whole affair to the mast. Careful examination of the photos will show the details.

The elements are fastened to the boom after carefully checking the spacing. In addition, make sure you have all the elements lined up horizontally with each other. If the array is mounted on a couple of boxes or sawhorses, an inexpensive level can be used to adjust the elements and line them up properly. When all the elements are mounted, the

ends of the boom will droop. An upright made from angle iron is mounted at the center of the boom mount. A large eye-bolt is mounted at the top of this upright and two wire braces are run out from it to the ends of the boom. To prevent rusting, the wires should be bronze or aluminum. In addition, they are broken up with small strain insulators to eliminate any resonance difficulties. A small turnbuckle is installed on each wire and adjusted until the boom is straight and level.

There is also a tendency for the boom to whip sideways. This is overcome by another angle brace at the center. This one is bolted at right angles to the boom mount. Four bracing wires are run from it part way out the boom. Four turnbuckles are used to adjust wire tension until the boom is straight and rigid.

When the wires are all taut, the boom is very firm and there is no noticeable flexing. Since I used bronze wire, I wrapped heavy vinyl insulation around the wire where it is looped around the ends of the aluminum boom. These two metals set up an electrolyt-

The assembled beam. The driven element is to the left with the gamma-match tuner. The wire bracing provides rigidity.

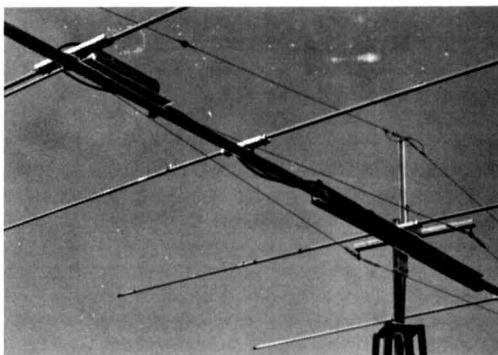

ic action, especially in a salt-air atmosphere, which will eventually weaken the beam.

### the remotely-tuned gamma match

The mount for the gamma-match tuner is made from a thin aluminum plate. This plate is mounted on the boom between the driven

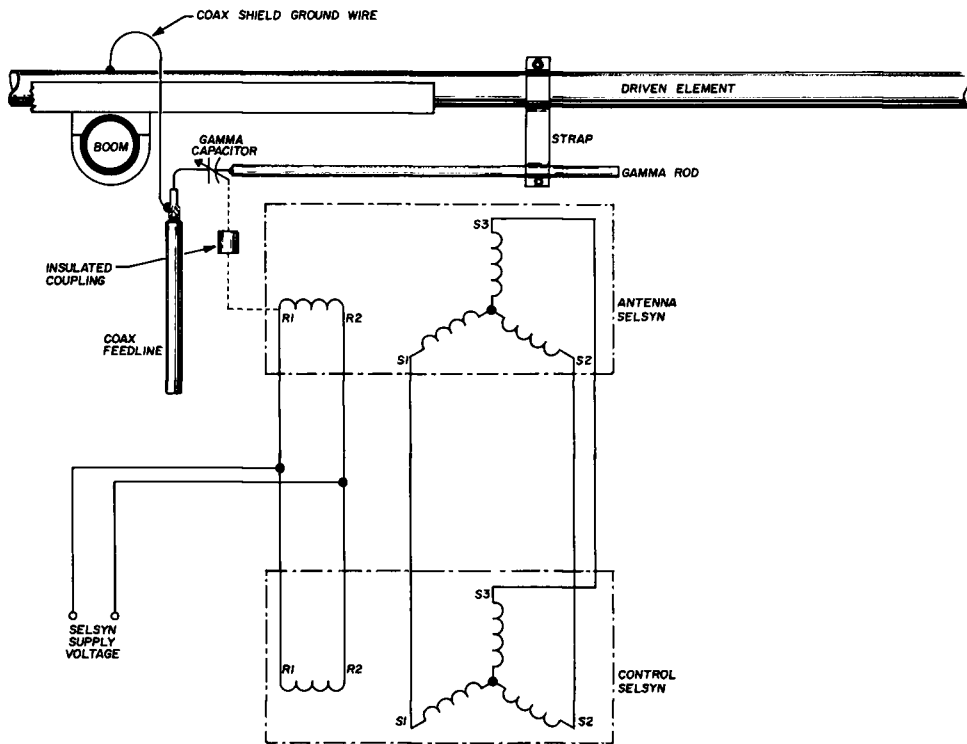

fig. 2. Wiring diagram of the remotely-tuned gamma match and its control system.

element and the first director. The gamma tuner is actually the heart of the beam, but it is very simple to build. It consists of the usual gamma capacitor, driven by a selsyn motor. If you are not familiar with selsyn motors, it is a device which can be remotely controlled through a five-wire cable which is connected to a similar unit. When the system is energized, the shaft of one unit turns until it is in electrical synchronism with the other. Moving one shaft will cause the other shaft to move exactly in step.

In the remotely-tuned gamma match, the capacitor which is coupled to the shaft of the antenna selsyn will exactly follow adjustments of the controlling selsyn in the shack. By watching an SWR meter in the comfort of your house, you can turn the selsyn shaft and automatically adjust the gamma capacitor on top of the tower. Although it might be simpler to use a small reversible motor for this application, the correct point for the gamma capacitor is very critical. It would be difficult to control a motor accurately enough to ad-

just the gamma match for an SWR of 1:1. The precise control afforded by the selsyn makes this method much more acceptable.

Ordinary receiver spacing is satisfactory for the gamma capacitor, but the larger spacing will guard against corrosion which may short out the plates after a long period of time. Let the climate be your guide!

To construct the gamma match, I used a pair of surplus selsyns along with a fairly wide-spaced 50-pF capacitor. Suitable selsyns are available from almost any surplus supply house. The antenna selsyn and gamma capacitor were coupled together with an **insulated** coupling and enclosed in a piece of aluminum vent pipe which was intended for electric clothes dryers. This pipe can be opened for easy installation of the gamma-match components and resealed with the locking lip built into the pipe. Two discs made from 1/4-inch plexiglass are cut to fit snugly into the ends of the pipe. The capacitor must be insulated from the vent pipe, so it's mounted directly to one plexiglass disc. The coaxial input connector is also mounted on the disc. An aluminum strap is used to connect the capacitor to a large bolt

which passes through the disc to the gamma rod. **Fig. 2** shows the wiring diagram of the gamma match; the photos show its construction.

The second disc is mounted in the opposite end of the vent pipe, and the control cable is passed through it to the selsyn. The selsyn body will usually have some sort of mounting lip which prevents it from fitting snugly into

**Disassembled remotely-controlled gamma-match tuner.**

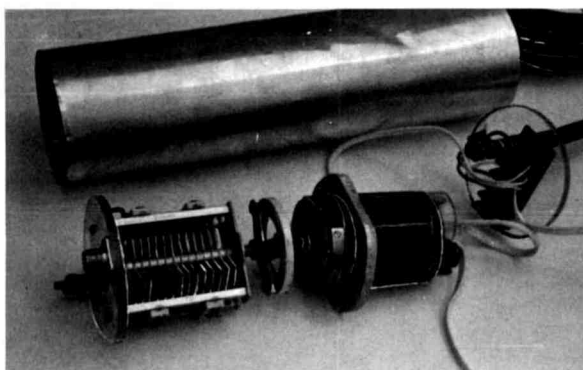

able compound to small cracks and openings. I used ordinary rubber-to-metal cement.

The gamma-match was mounted on my beam with two large surplus Marmon clamps around the vent-pipe enclosure. The bolt ends of the clamps acted as mounting bolts through the plate on the boom. My particular gamma match was fairly heavy because of the large selsyn and capacitor, but any small units may be substituted. Selsyns may be rated for 110, 24, or 36 volts ac, but 110-Vac units eliminate step-down transformers. Use 60-Hertz units to avoid any heating and torque problems. Power is only applied to the units for a short time when tuning up the beam; after that, you only have to adjust the gamma match after a wide shift in operating frequency.

### tuning it up

Tune-up must be done with the beam at least ten feet above the ground. The gamma

**fig. 3. Gamma match adjustment. The use of a quarter-wave section of 52-ohm coax is discussed in the text.**

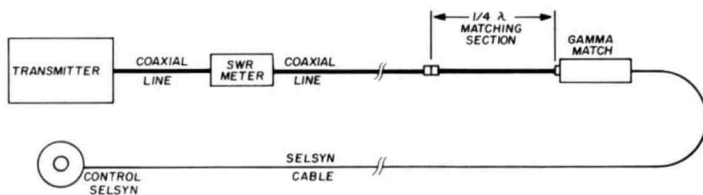

the vent pipe, so small pieces of wood or plexiglass are used to wedge it firmly in place. The selsyn body must be firmly clamped in place so it will rotate the capacitor.

The antenna and control selsyns are then connected together temporarily and checked. As soon as 110 Vac (or whatever voltage is required by the selsyns used) is applied to their rotors, the two shafts should synchronize immediately. Turning one shaft will cause the other shaft to follow exactly. If the two shafts rotate in opposite directions, reverse the connections to any **two stator** terminals (marked with the letter "S") of either selsyn. This isn't too important in this application since it doesn't really matter if they turn in opposite directions or not.

When the gamma-match assembly is operating properly, the whole unit should be sealed against moisture by applying a suit-

match is adjusted by setting the length of the gamma rod to about 20 inches and adjusting the capacitor for minimum reading on the SWR meter. See **fig. 3** for the set-up required. The setting of the rod will depend a lot upon the number of elements and their spacing, so it may be necessary to try several taps along the driven element before getting the SWR down below 1:1.5. It should be possible to get it down to 1:1 at a point close to the design frequency, but it will rise as the transmitter is tuned up or down from this point.

You can get a good idea of the bandwidth by plotting the SWR over a band of frequencies without readjusting the gamma match. With the remote match of course, it is no problem to readjust for minimum SWR. Remote tuning is not necessary, but it does add greatly to operating convenience. If it is

left out, all adjustments must be made before the beam is in its final position on the tower; otherwise, the capacitor cannot be reached.

Adjustment of element lengths can be done in order to get the best possible gain or front-to-back ratio, but the process is long and tedious and simply not worthwhile. If the elements have been cut and measured properly, they will be very close to optimum dimensions.

The beam may be fed with either 52- or 75-ohm coaxial cable. However, the more elements you use, the lower the radiation resistance at the center of the driven element.

**Workbench setup for testing the remotely-controlled gamma-match tuner.**

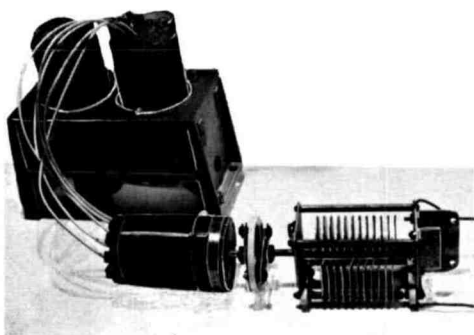

To match the lower resistance, the gamma rod must be tapped farther and farther out on the driven element to obtain a proper impedance match. To overcome this problem, a quarter-wavelength of lower impedance coaxial cable may be used to produce a terminal impedance which is lower than that of either the feedline or the quarter-wave section.

I used 75-ohm feedline in my installation, connected to an 8-foot section of 52-ohm line. This provides an output impedance of about 27 ohms, a much closer match to the beam impedance than afforded by either the 52-ohm or 75-ohm line by itself. The gamma match can easily compensate for any remaining mismatch, and the gamma rod becomes fairly short (and easier to adjust). Although the quarter-wave matching line would normally restrict the beam to a rather small bandwidth, the remote gamma tuning overcomes this problem very nicely. I can adjust

my seven-element version for a maximum SWR of 1.7:1 over the range from 28.0 to 29.0 MHz. Over 75% of this range the SWR can be held below 1.5:1.

## results

The gain and front-to-back ratio of the antenna are excellent. Calibrated tests indicate a front-to-side ratio of a little over 40 dB, a front-to-back ratio of 31 dB, and two very deep nulls of 60 dB about 10 degrees off the axis of the beam to the rear. I can't explain this latter characteristic, but it makes me very happy in any case! Repeated tests show this peculiar pattern is definitely there, but it may not necessarily be the same on a duplicate beam.

Forward gain figures are not available yet because I have not erected a reference dipole, but based on the other known figures, it should be on the order of 12 dB. On-the-air results have been most pleasing!

## ham radio

**The gamma-match assembly.**

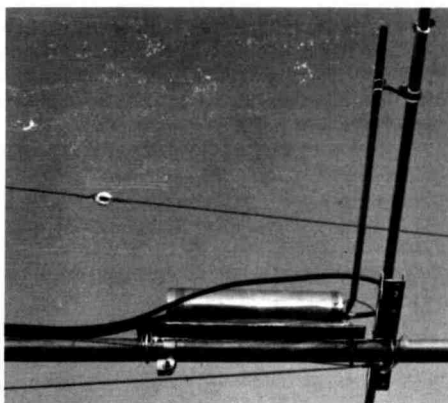

## editor's note

Although VE1TG used the remotely-tuned gamma match on a ten-meter beam, the same technique could be used just as well on other antennas with built-in tuning sections.

Normally **ham radio** will not publish antenna gain figures because of the many vagaries in making accurate measurements. The figures presented here represent an average of many on-the-air measurements and are given only as a guideline.

**WIDTY**



# ...EVOLUTION!



## THE NEW SWAN 500C 5 BAND—520 WATT TRANSCEIVER SSB-AM-CW HOME STATION-MOBILE-PORTABLE

The new model 500C is the latest evolutionary development of a basic and well proven design philosophy. From the very beginning, with the introduction in 1961 of the first single band SSB Transceiver, Swan has followed a steady course of improvement by evolution. You might think that we would finally reach the point of leaving well enough alone, but with some 18 licensed hams in the engineering, sales and production departments of our organization, it just isn't possible. Thus, the new model 500C, with greater power and additional features for even more operator enjoyment.

RCA recently introduced a new heavy duty "blast rated" tetrode, the 6LQ6. With a pair of these rugged tubes the final amplifier operates with increased efficiency and power output on all bands. PEP input rating of the 500C is conservatively 520 Watts. Actually, an average pair of 6LQ6's reach a peak input of over 570 Watts before flat-topping!

Further refinement of the famous Swan VFO results in even greater mechanical and thermal stability and more precise dial calibration. Custom made planetary drives, machined to extremely close tolerance, provide velvet smooth tuning.

The 500C retains the same superior selectivity, of course, that we have been offering. The filter is made specially for us by C-F Networks, and it's no secret that it is a better filter than is being offered in any other transceiver today. By moving the I.F. to 5500 KC, and increasing the number of tuned circuits in the receiver, we have

achieved substantial improvement in image and spurious rejection. These improvements, coupled with additional TVI filtering, result in what we believe is the cleanest transceiver on the market.

For the CW operator the 500C includes a built-in side-tone monitor. Also, by installing the Swan Vox Accessory (model VX-2) you will have break-in CW operation. Thus, the model VX-2 now fulfills a dual function, both automatic voice control and break-in CW keying. Grid block keying of a pure CW carrier is employed with off set transmit frequency.

The 500C embodies the Swan's well known dedication to craftsmanship, performance and reliability, with a service policy second to none. When you visit your Swan dealer and look over the 500C, we are sure that you will be glad we couldn't 'let well enough alone.'

**\$520**

**SWAN 350C** Our improved standard model, now in production, and still only **\$420**

### ACCESSORIES

#### MATCHING AC POWER SUPPLY

Model 117XC ..... **\$95**

#### 12 VOLT DC POWER SUPPLY

Model 14-117 ..... **\$130**

**MODEL 410 FULL COVERAGE EXTERNAL VFO** ..... **\$95**

**MODEL 22 DUAL VFO ADAPTOR** ..... **\$25**

**MODEL 405X CRYSTAL CONTROLLED MARS OSCILLATOR** **\$45**

**MODEL VX-2 VOX and BREAK-IN CW UNIT** ..... **\$35**

SEE IT AT YOUR  
SWAN DEALER



**SWAN** ELECTRONICS  
Oceanside, California

A SUBSIDIARY OF CUBIC CORP.

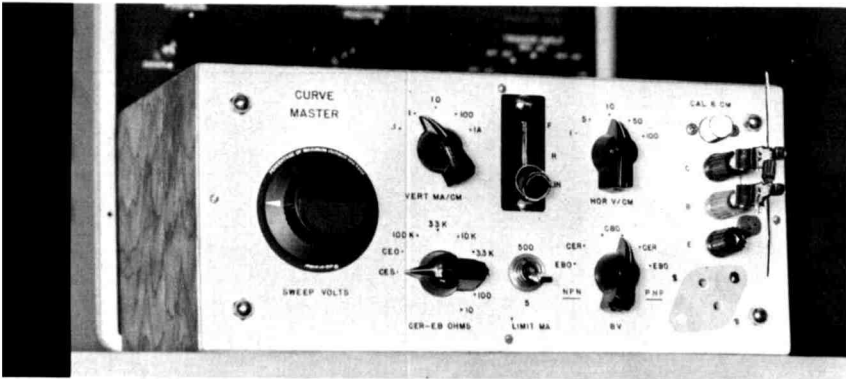

## the curve master

An  
oscilloscope  
attachment for tracing  
the characteristic  
curves of  
active  
devices

Tom Lamb K8ERV, 1066 Larchwood Road, Mansfield, Ohio 44907

The **curve master** is an attachment for an oscilloscope which will display the volt-ampere characteristics of almost any two-terminal device as well as most transistors. As examples, here are some of the devices that can be electrically displayed:

1. Common signal and power diodes (silicon, germanium, selenium, gallium arsenide, etc.)
2. Zener diodes.
3. Tunnel diodes and back diodes.
4. Neon bulbs and V-R tubes.
5. Photocells (photo-resistors).
6. SCR's and light-activated-switches (LAS).
7. Thyrites and thyrectors.
8. Transistors; NPN and PNP, germanium or silicon.

The range of the **curve master** is 1000 volts reverse, and several amperes forward. With a little experience, you can identify a diode or transistor as silicon or germanium by their unique forward-conduction and reverse-leakage characteristics. Since they vary quite widely, semiconductor ratings should always be checked. With a curve tracer you can easily pick out especially good units from your stock for special uses. The **curve master** will check and grade surplus and bargain devices—and may even convince you not to buy any more!

## how it works

The basic circuits of a two-terminal curve tracer are shown in **fig. 1**. An ac voltage is applied to the device under test, and at the same time, to the horizontal axis of an oscilloscope. Any current drawn by the device is displayed as a voltage drop on the vertical axis. The horizontal voltage can be increased beyond the device's breakdown point without harm, since the voltage sweeps this region very quickly and the breakdown current is limited by circuit resistance. Since the test voltage goes both positive and negative, both the forward and reverse regions of the device are displayed as shown in **fig. 1A**.

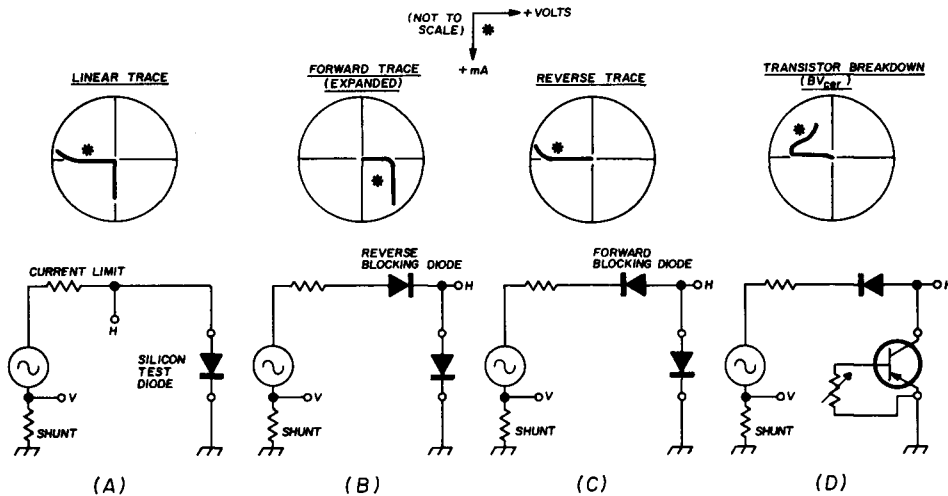

**fig. 1.** The basic two-terminal curve tracer and several different types of traces which may be obtained with it.

A series diode can be added (**fig. 1B** and **1C**) to eliminate either part of the trace. This permits expansion and detailed examination of the remaining part, and also establishes the start of the trace for voltage measurement reference.

A typical transistor set up is shown in **fig. 1D**. Each transistor junction is checked individually. The **curve master** is made up of these simple circuits with shunts and multipliers to allow a wide range of readings on any scope. It will display voltages from less than one volt to 1000 volts, and current from less than 100 micro-amps to several amperes.

## the circuit

The complete schematic of the **curve master** is shown in **fig. 2**. The 750-Vac transformer supplies the forward and reverse test

voltages. Diodes D1 and D3 are the blocking diodes described above. S3 selects the region to be displayed—forward, reverse or both. S2 selects the value of the shunt resistance to give vertical ranges of 0.1, 1.0, 10, 100, and 1000 mA per division. S4 has two functions: sections C and D are the horizontal voltage range multipliers, providing ranges of 1, 5, 10, 50, and 100 volts per division; sections A and B select the current-limiting resistances, in two ranges, 5 and 500 mA maximum, as selected by the limit switch S1. S6 selects the transistor junction to be displayed and reverses the test polarities for NPN or PNP devices. S7 adjusts the base-emitter resistance

for the  $BV_{cer}$  tests. An internal calibrator (S5 and D4) is provided for calibrating the scope.

## construction

There is nothing critical about the layout. Just remember that up to 1 kV appears across the switches and test jacks, so everything should be well insulated. Diode D3 must be rated above the maximum test voltage and may be made up of several 400- or 600-volt TV-type power diodes in series. D1 is a 50-volt or better diode rated at several amperes. D2 bypasses any reverse leakage from D1. The 750-Vac transformer may be any small receiver transformer with a secondary voltage of at least 750 volts (1 kV peak). All low-voltage windings are series connected to supply the low-voltage, high-current, forward sweep. If the secondary voltage is too low,

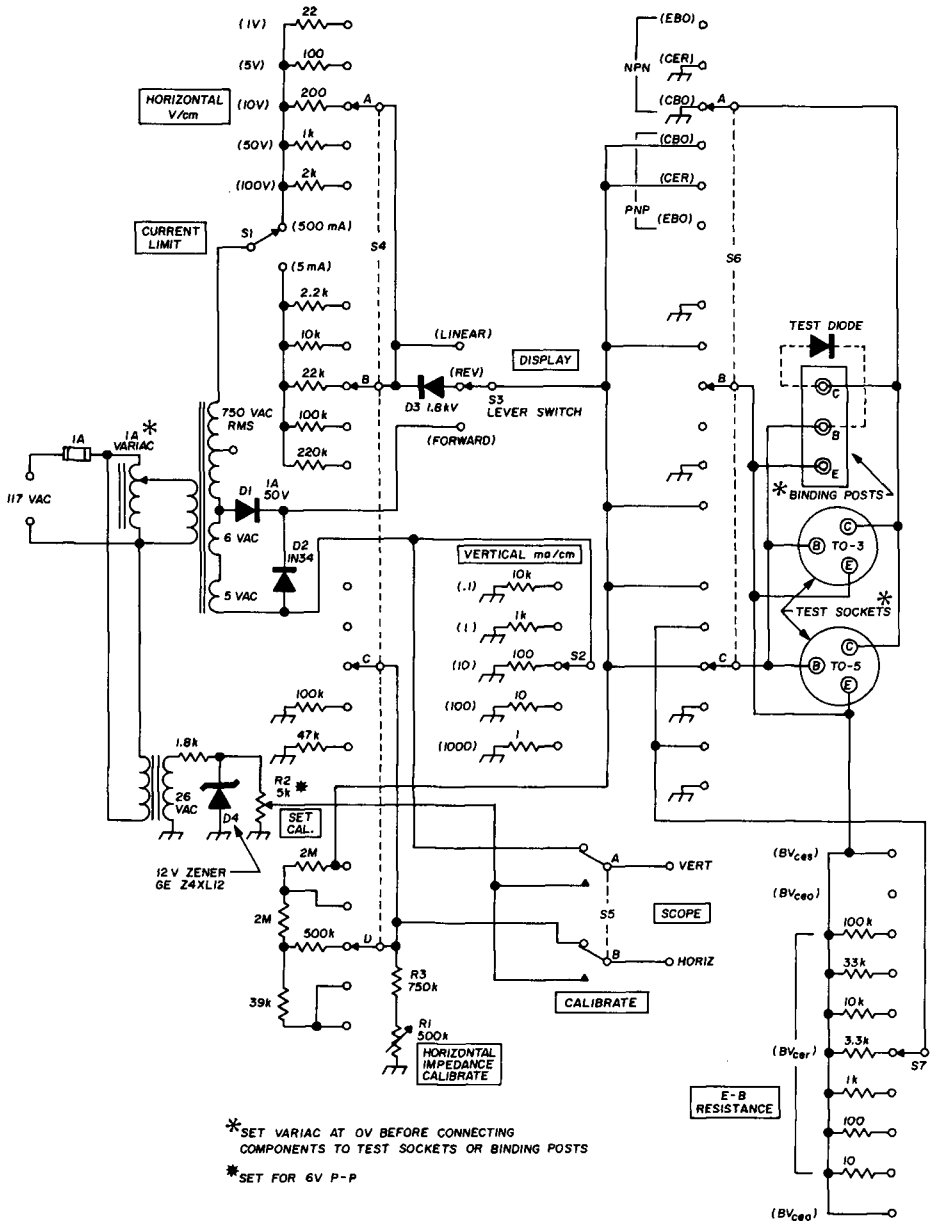

- S1 SPDT toggle switch (Current Limit).
- S2 SP5T rotary shunting switch (Vert. mA/cm).
- S3 SP3T lever switch (Forward-Reverse-Linear).
- S4 4P5T shunting rotary switch (Horiz. V/cm).

- S5 DPDT push-button switch (Push to Calibrate Scope).
- S6 3P6T rotary switch (Breakdown Voltage Circuit).
- S7 SP10T rotary switch (Base-Emitter Resistor Selection).

fig. 2. Schematic diagram of the curvemaster.

use the over-voltage connection on the Variac. The test connections are brought out to five-way binding posts and to both miniature and power transistor sockets, as shown

in the photograph. The 5k set calibration and 500k horizontal impedance pots are screw-driver adjustments mounted on the rear of the chassis.

## calibration

The **curve master** can be used with any scope, but for the calibrations to be correct it should meet these specifications:

Vertical sensitivity—one volt per major division or better.

Horizontal sensitivity—one volt per major division or better.

Horizontal input impedance—over 500k.

The scope does not have to be direct coupled, although this feature is desirable for certain displays.

Only two controls must be calibrated—R1 and R2. R1 sets the horizontal impedance at exactly 500k and is adjusted first. Turn the **Variac** to zero and connect the **curve master** to your scope. Set the scope's vertical gain to zero, the horizontal selector to external and the horizontal gain about half open. Set S3 (**display**) to linear and S4 (**horizontal**) to 1

fig. 3. OA2 curve. 50 V/cm H, 10 mA/cm V.\*

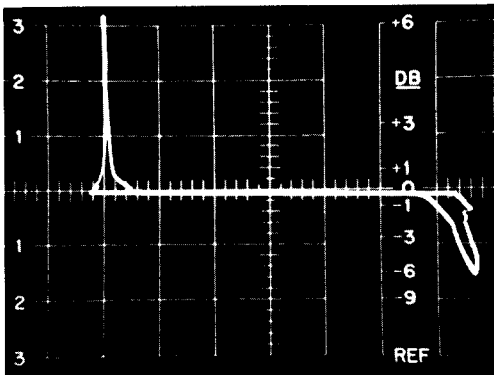

volt. Advance the **Variac** to obtain exactly full-scale horizontal deflection. Change S4 to 5 volts, and adjust R1 for exactly 1/5-scale deflection. If your scope's horizontal impedance is not around 1 megohm, it may be necessary to change the value of R3 to obtain 1/5-scale deflection. The horizontal multiplier, S4, is now adjusted. This setting must be checked if the **curve master** is used with another scope.

\* 50 V/cm H, 10 mA/cm V indicates the curve-master is set for 50 volts per centimeter horizontal and 10 mA per centimeter vertical on the oscilloscope. The graticule marks on the oscilloscope shown in the photographs are one centimeter apart. The curve to the right of center is the forward characteristic; to the left, reverse. In some cases different sweep widths are used for the forward and reverse traces.

The **curve master** has an internal calibrator to set up the scope gain controls. This calibrator must be set for exactly 6 volts, peak to peak. If you have a calibrator for your scope, it is still convenient to use the **curve master's**. R2 may be set for a 6-volt calibrating waveform in two ways. If you have a calibrator or a scope with a calibrated vertical amplifier, adjust R2 as described in the next paragraph.

Calibrate the scope for 1 volt per major division. Connect the **curve master** and press S5 (**calibrate**). A sloping line will appear on the screen. Adjust R2 for a vertical distance of exactly six major divisions.

If no external calibrator is available, a good OA2 voltage regulator tube can be used. Set the scope vertical gain to roughly 1 volt per division. Connect the **curve master** to the scope. Attach the collector jack to pin 7 of the OA2 and the base jack to pin 1. Set the switches as follows: S1 to 500 mA, S2 to 10 mA/division, S3 to reverse, S4 to 50 volts per division, S6 to PNP-CBO. Advance the **Variac** and the horizontal gain control on the scope to form a trace like the left half of **fig. 3**. The right edge of the base line will be a bright spot. Using the horizontal gain control, set the vertical part of the trace exactly three divisions from the trace's right edge. The horizontal system is now set at 50 volts per division. Turn the vertical gain and the **Variac** to zero, push S5 and adjust R2 for a six-division horizontal deflection. The instrument is now calibrated.

## using the curve master

Caution: dangerous voltages may be present at the test terminals and sockets. Always turn the **Variac** to zero before making any connections. It is a good idea to start all tests with the limit switch in the 5-mA position to prevent possible damage to the device being tested.

Let's get used to the operation by checking several devices in some detail, using the photos as examples.\* Connect the **curve master** to the scope and set it for external

\*These photos were taken with a Polaroid Pacemaker, 3000 speed film, and both plus-4 and plus-2 close-up lenses. The traces were displayed on a Knight KG-2000 scope, using an exposure of 1/4 second at f8.

horizontal input. Push the calibrate switch (S5), and set both scope gains for six divisions of horizontal and vertical deflection.

Connect an NE-2 or other small neon bulb to the collector and base terminals. Two-terminal devices are always connected to these jacks and the BV switch set on CBO-PNP. Changing to CBO-NPN merely reverses the test device's connections and may be switched to reverse a mis-connected device or to examine its reverse characteristic. Since a neon bulb operates at about 60 volts and 1 mA, set the Vertical mA per division switch (S2) to 1, and the Horizontal volts per division switch (S4) to 50. The limit switch (S1) must be in the 5 mA position. Set the display switch (S3) to linear, and advance the Variac to obtain the trace shown in fig. 4 which is displaced below center for a clearer photograph.

Assume the sweep voltage from the transformer is zero, and increasing positively. The trace will start in the center of the screen and move to the right along the baseline. Until the voltage increases to about 75 volts, the neon draws no current and there is no vertical deflection. At 75 volts, the bulb fires, suddenly decreasing the voltage and increasing the current throughout the bulb. The trace moves (too quickly to photograph) down and to the left, joining the lower branch. The bulb is now lighted and conducting the current permitted by the circuit resistance. As the sweep voltage increases, the current sky-rockets downward (positive), reaching the maximum allowed by the Variac setting. In fig. 4 the maximum current is 1.8 mA.

The sweep voltage now decreases. The

fig. 4. NE-2 curve. 50 V/cm H, 1 mA/cm V.

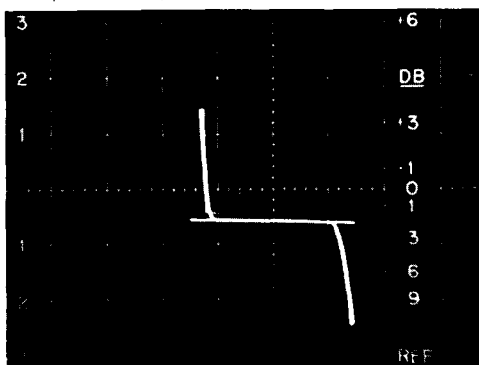

trace moves back along the same path until the current reaches zero at 55 volts, and the bulb extinguishes. On the reverse cycle the same events occur except that now the second electrode is lighted, and its characteristic is traced. The two electrodes' characteristics are similar but may not be identical. The curve master can compare these two characteristics.

fig. 5. Left to right: high-conductance germanium diode, silicon diode, low-conductance germanium diode. 1 V/cm H, 10 mA/cm V.

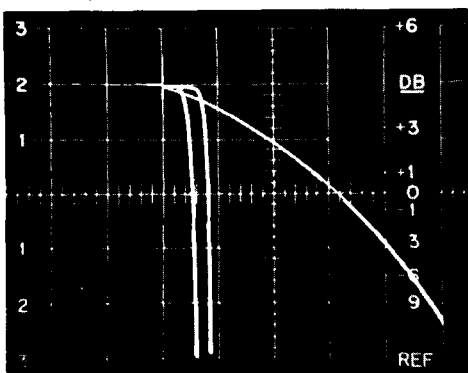

Now change the display switch to reverse, so only the left half of the trace is displayed. The zero-voltage, zero-current point is now the bright dot at the right end of the baseline. This point can be kept in the center even on an ac-coupled scope. Only the second electrode, being displayed, is lighted. If the BV switch is changed from CBO-PNP to CBO-NPN, the first electrode will light and be displayed, but flipped to the screen's left—exactly in place of the previous trace. The two electrode characteristics can be compared by super-position if the BV switch is rapidly alternated between PNP and NPN.

Let's look again at the V-R tube. Connect an OA2 as described in the calibration section. Use the linear display, 500 mA limit, 10 mA per division vertical and 50 volts per division horizontal to obtain a trace like fig. 3. The left-hand portion of the curve is the normal regulation connection, showing very little voltage variation from 8 to 30 mA. A backward-connected V-R tube would give very little regulation, as shown by the right half of the trace. Try flipping the BV switch to flip the trace. Now try it with the display

switch in the reverse position. For an expanded view of the regulating region, set the horizontal switch to 10 volts per division and re-position the trace on the screen.

Now we will look at a typical germanium diode, such as a 1N34. Turn the Variac down, the limit to 5 mA, the vertical to 1 mA per division, and the horizontal to 50 volts per division. Advance the Variac to obtain the trace

fig. 6. T1 U213 silicon diode. Forward: 1 V/cm H, 100 mA/cm V; reverse: 10 V/cm H, 10 mA/cm V.

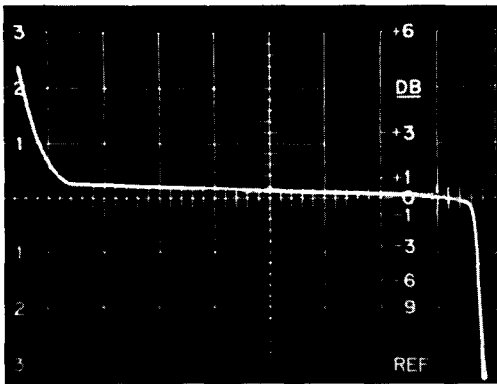

shown in fig. 1A using a linear display. Now, change the display to forward and reduce the horizontal to 1 volt per division. The expanded forward characteristics will look like one of the outer traces of fig. 5, depending on the particular diode used. Notice that both low and high conduction diodes show conduction starting at about 0.2 volts. The center curve is typical of silicon diodes, which begin conduction at about 0.6 volts. These unique forward curves can be used to identify the type of diode that you are testing.

### typical curves

Fig. 6. and 7 are double exposures with the forward and reverse curves photographed separately at different settings. The reverse curve of a silicon TV type power diode, the TI U213, is shown in fig. 6. Notice the fairly soft breakdown at 660 volts, well beyond the 400-volt rating. Compare this with the very sharp zener diode break in fig. 7. The zener diode is designed to operate in the reverse region, the power diode is not. An old-fashioned selenium rectifier stack curve is shown in Fig. 8. Compare the high reverse

leakage and high forward-voltage drop with the silicon unit.

Now, let's try some transistors. The important voltages here are:

**BVcbo** Breakdown voltage between collector and base with the emitter open.

**BVebo** Breakdown voltage between the emitter and base with the collector open.

**BVces** Breakdown voltage between collector and emitter, with the base connected to the emitter.

**BVcer** Breakdown voltage between collector and emitter, with resistance between base and emitter.

**BVceo** Breakdown voltage between collector and emitter, with the base open.

For discussions of the exact meanings and uses of these ratings, see the General Electric

fig. 7. Mallory ZA51 zener diode. Forward: 1 V/cm H, 100 mA/cm V; reverse: 10 V/cm H, 10 mA/cm V.

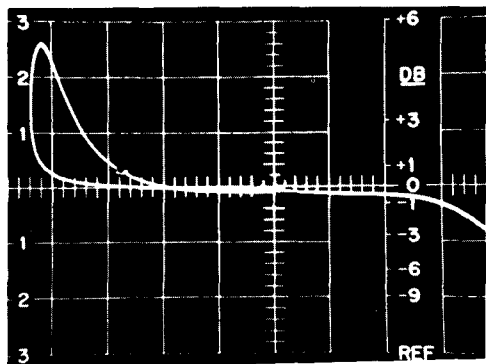
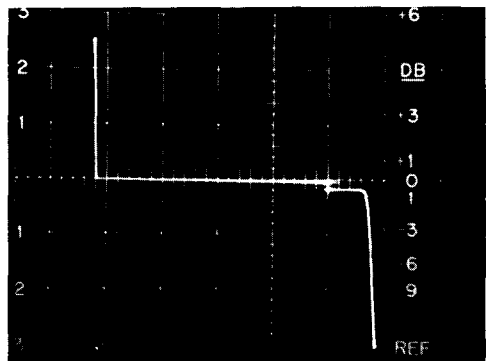
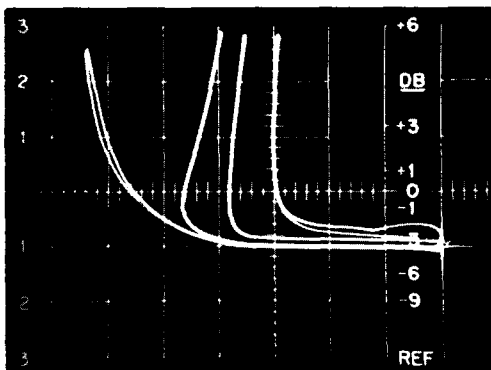

fig. 8. Selenium rectifier. Note relatively poor forward and reverse characteristics. Forward: 1 V/cm H, 100 mA/cm V; reverse: 50 V/cm H, 10 mA/cm V.

Transistor Manual or the Motorola Power Transistor Handbook.

First, a power transistor. Start with these settings: display, reverse; limit, 500 mA; vertical, 10 or 100; horizontal, 50 or 100. Set S7 to BVces and S6 to BVcbo-PNP. Plug a power transistor into its socket and advance the Variac. Don't forget to connect the collector to the socket with a screw. You should see the left-hand curve of fig. 9. If you only get a vertical trace, either the collector-base junction is shorted, or you have an NPN unit. Try the NPN position of S6. Most power transistors are PNP.

fig. 9. 2N554 power transistor. Left to right: BV<sub>ceo</sub>, BV<sub>ces</sub>, BV<sub>cer</sub> (100 ohm), BV<sub>cco</sub>. 10 V/cm H, 10 mA/cm V.



The collector diode rating, BVcbo, is the voltage at the vertical part of the curve—in this case over 65 volts. Not bad for a 2N554, rated at 15 volts! Now turn S6 to BVcer. In this position the collector-to-emitter characteristic is traced, with the base-to-emitter resistance selected by S7. When S7 shorts the base to the emitter, you have BVces. When S7 opens the base, you have BVceo. In other positions of S7 you have BVcer, with S7 setting the value of R. For transistor quality checks, the value of R from the manufacturer's data sheet for BVcer should be used.

For circuit design, set S7 to the value to be used and check the actual curve for the transistor. BVebo is not shown, but will be displayed with S6 set to that position. This is the maximum reverse input (base-to-emitter) voltage that may be used if not already limited by BVcbo. BVebo is important in reversed-bias applications such as blocking

fig. 10. 2N2924 silicon transistor. Top to bottom: BV<sub>ces</sub>, BV<sub>ceo</sub>, BV<sub>cer</sub> (33k), BV<sub>cer</sub> (10k), BV<sub>cbo</sub>. 50 mA/cm H, 1 mA/cm V. Traces displaced from origin for clarity.

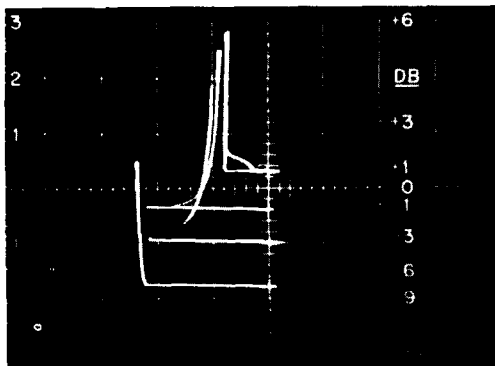

oscillators, where a very large reverse-voltage spike can occur.

A small-signal silicon planar transistor exhibits slightly different curves. The GE 2N2924 NPN device is traced in fig. 10. Notice the sharp breakdowns in the two BVcer tests. The lowest break is at 40 volts, while the transistor is only rated at 25 volts. Don't forget to use the 5-mA limit with low-power devices.

fig. 11. 1N34 germanium diode. Forward: 1 V/cm H, 1 mA/cm V; reverse: 50 V/cm H; 1 mA/cm V.

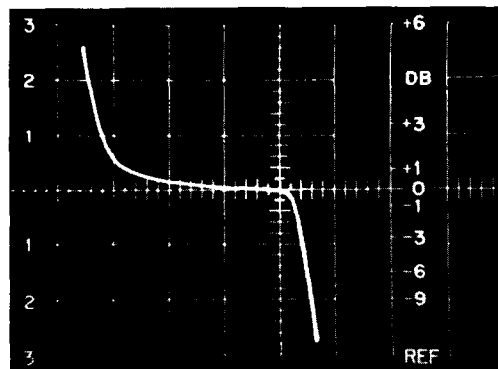

The rest of the photos show traces of less common devices. If an external bias supply is used, the complete collector family curves can be displayed on a dc-coupled scope. With external bias and filament supplies, it is possible to display vacuum and gas-tube family curves as well.

ham radio



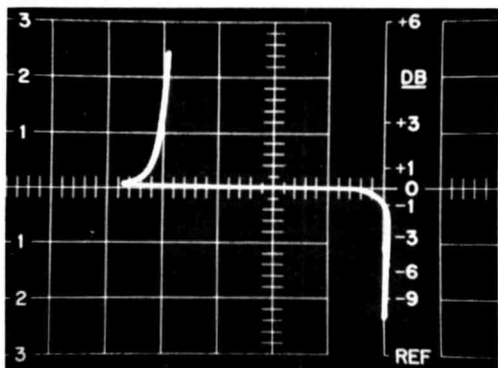

10 V/cm H, 1 mA/cm V.

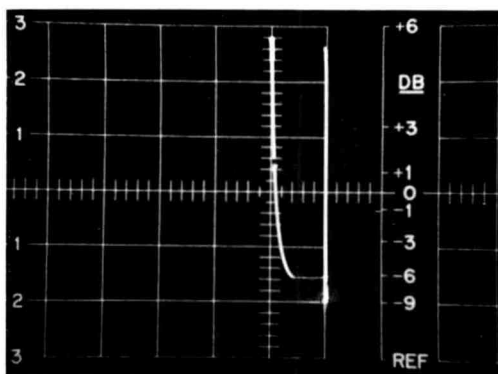

1 V/cm H, 1 mA/cm V.

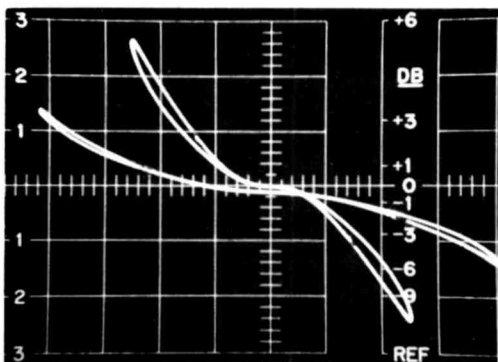

100 V/cm H, 1 mA/cm V.

Top to bottom: TI-42 trigger diode, 1N653 tunnel diode, photocell showing nonlinear resistance at different light levels.

# NOW!

## IN THE WEST

**Now... 2000 Watts P.E.P.**  
**Full Power/Minimum Size**  
**FOR APARTMENTS • SUBURBAN HOMES**  
 Marine and Portable Operation  
*Packaged for APO and FPO Shipping*

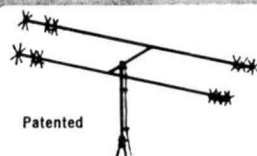

Patented

**6-10-15-20 METERS**

The time proven B-24 4-Band antenna combines maximum efficiency and compact design to provide an excellent antenna where space is a factor. New end loading for maximum radiation efficiency. No center loading.

|                  |                   |
|------------------|-------------------|
| Bands            | 6-10-15-20 Meters |
| Power Rating     | 2000 Watts P.E.P. |
| El. Length       | 11'               |
| Turn. Radius     | 7'                |
| Total Weight     | 11 lbs.           |
| Single Feed Line | 52 ohm            |
| SWR at Resonance | 1.5 to 1.0 max.   |

**Model B-24**  
**Net \$59.95**

### MULTIBAND COAXIAL ANTENNA for 6 - 10 - 15 - 20 METERS

Needs no ground plane radials. Full electrical  $\frac{1}{2}$  wave on each band. Excellent quality construction. Mount with inexpensive TV hardware. Patented.

|                  |                   |
|------------------|-------------------|
| Power Rating     | 2000 Watts P.E.P. |
| Total Weight     | 5 lbs.            |
| Height           | 11'               |
| Single Feed Line | 52 ohm            |
| SWR at Resonance | 1.5 to 1.0 max.   |

**Model C4 Net \$34.95**



## Free Delivery On "MINI BEAMS" From

# QUEMENT ELECTRONICS

1000 SOUTH BASCOM AVE.  
 SAN JOSE, CALIFORNIA  
 95128  
 PHONE 294-0464 SINCE 1933

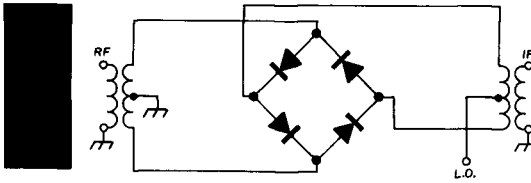

fig. 1. Basic double-balanced mixer circuit. Note that the diodes are not connected in a diode bridge.

## double-balanced mixers

how  
to use this fascinating  
new electronic  
stuntbox  
in  
amateur  
equipment

Jim Fisk W1DTY, RFD 1, Box 138, Rindge, New Hampshire 03461.

If you are tired of fooling around with transistors and bored by integrated circuits, you might be interested in a new electronic stuntbox that is currently on the market—the double-balanced mixer. These new gadgets are small (the unit I have in my hand is half an inch wide,  $\frac{3}{8}$ -inch high and about  $\frac{7}{8}$ -inch long), broadband, typically from 500 kHz to 200 MHz, and can perform all kinds of electronic tricks. To say that they are versatile is the understatement of the year.

Broadband double-balanced mixers can be used as suppressed-carrier modulators, deriving sum and difference products of two input frequencies; they can serve as up- or down-converters with appropriate filtering at the output, and they can be used as product detectors, phase detectors or voltage-controlled attenuators. In addition, they may serve as a-m modulators, pulse modulators or spectrum generators. To top it all off, they don't require a power supply. Interested? Read on.

While these broad-band double-balanced mixers have been available for several years, up until now their cost has been so high that they were completely out of the amateur picture. Although they are still quite expensive, the price has dropped to the point where many amateurs will be trying them in their projects.

### circuits and characteristics

The units presently available actually come in all shapes and sizes, from miniature units

**fig. 2. Conversion loss versus local-oscillator power for the Ultramatic Systems UM-1 double-balanced mixer in a 50-ohm system.**

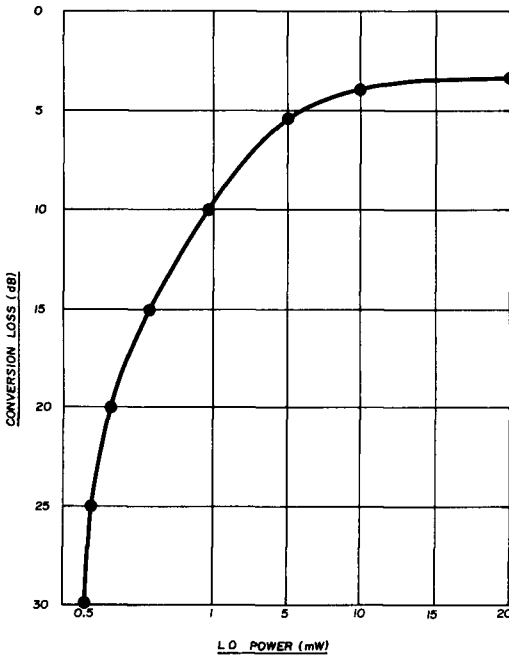

**fig. 3. A 20 - meter converter using the double-balanced mixer. The 75-pF capacitors in the rf stage may be ganged and tracking obtained by adjusting the two slug-tuned coils.**

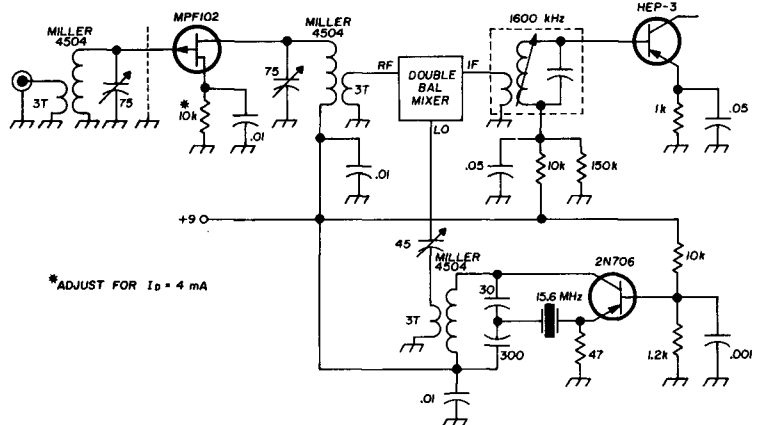

for printed-circuit mounting to larger units with built-in coaxial connectors. However, they all have one thing in common—their circuit. Evidently the manufacturers are afraid someone is going to copy their designs, because most of the units are hermetically sealed. However, the circuit shown in **fig. 1** is probably what you would find if you opened the thing up.

Schematically, it isn't that impressive—two transformers and a diode ring. Each of these components must work together to provide the desired isolation, frequency range, and conversion loss. The diodes aren't any garden variety units—often they're Schottky barrier diodes; and they are very closely matched. The transformers, usually toroidally wound, must be precisely balanced to obtain the desired operating characteristics. All these things contribute to the cost. For example, in a typical double-balanced mixer, up to 50 MHz the isolation between the rf and i-f inputs is 25 dB, isolation between rf and local oscillator is 40 dB, and isolation between the local oscillator and i-f is 35 dB.

Internal construction and engineering is also important to the frequency characteristics and conversion loss of the unit. The frequency range varies from manufacturer to manufacturer, as shown in **table 1**. These are the fre-

table 1. Double-balanced mixers suitable for amateur use.

| Manufacturer                    | Model No. | Frequency  | Insertion Loss | LO Isolation | Noise Figure |
|---------------------------------|-----------|------------|----------------|--------------|--------------|
| Adams-Russell <sup>1</sup>      | MLF-3     | .5-200 MHz | 8 dB           | 25 dB        | —            |
| Adams-Russell                   | MHF-3     | 10-500 MHz | 8 dB           | 25 dB        | —            |
| Comdel <sup>2</sup>             | CM101     | 1-30 MHz   | 6 dB           | 30 dB        | 6.5 dB       |
| Comdel                          | CM102     | 20-120 MHz | 7.5 dB         | 30 dB        | 8.0 dB       |
| Comdel                          | CM103     | 2-200 MHz  | 7.5 dB         | 30 dB        | 8.0 dB       |
| Ultramatic Systems <sup>3</sup> | UM-1      | .2-200 MHz | 6 dB           | 40 dB        | —            |

1. Adams/Russell-Anzac, 121 Water Street, Norwalk, Connecticut 06854.

2. Comdel, Beverly Airport, Beverly, Massachusetts 01915.

3. Ultramatic Systems Laboratory, P. O. Box 2143, Sunnyvale, California 94087.

quencies at which the unit is guaranteed to work within the limits of the other specifications. Usually they may be used at somewhat lower frequencies. For example, if the low-frequency limit is listed as 1 MHz, in all probability the unit will work satisfactorily down to several hundred kilohertz. Also, the i-f terminal is usually dc connected; this is very important. In some units you will find a series capacitor between the external terminal and the transformer center tap. With a straight dc connection as shown in fig. 1, the versatility is increased tremendously. Applications as a voltage-controlled attenuator, a-m modulator, phase modulator and phase detector are impossible without it.

If you look closely at the specifications for these units, you'll find that most of them are designed for 50-ohm systems. However, this doesn't mean that the input and output impedance have to be precisely matched. The major effect of increasing the load im-

pedances will be to raise the low-frequency cutoff of the device.

As shown in fig. 2, the conversion loss of the double-balanced mixer is very dependent upon the local oscillator drive that is supplied. This curve is typical of the Ultramatic Systems UM-1 double-balanced mixer, but units from other manufacturers have similar curves. In this case, when the local oscillator power is less than about 5 mW, conversion loss increases very rapidly. As local-oscillator power is increased above 5 mW, conversion loss does not decrease significantly. For most circuits, optimum operation will occur somewhere in the neighborhood of 5 to 10 milliwatts of local-oscillator drive.

### frequency converters

One of the most important applications for double-balanced mixers is as a mixer or frequency converter stage in a communications receiver. In this case (fig. 3), the rf

fig. 4. The 144-MHz converter with a double-balanced mixer stage. For more gain, another rf stage may be added.

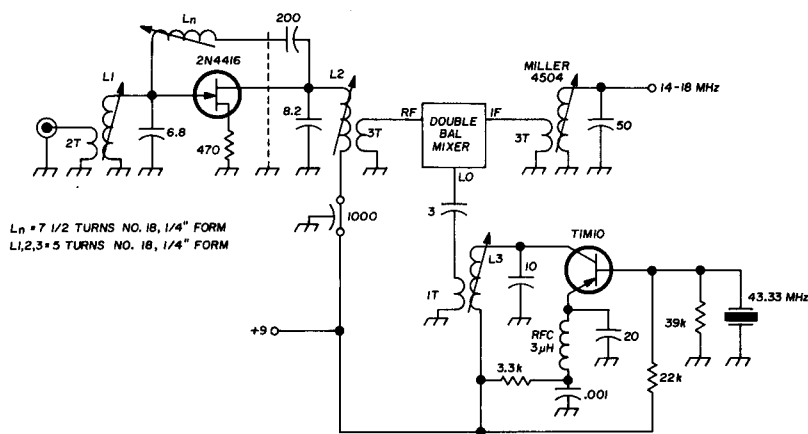

signal from the first rf amplifier is fed into the rf terminal, the high-frequency oscillator is connected to the local oscillator terminal, and the i-f output is taken off the i-f terminal. One of the big advantages of this circuit is that very little local oscillator power reaches the i-f terminal—it is very highly suppressed. In the circuit in **fig. 3**, about 6 mW of power at the local oscillator terminal provided the best results; this is adjusted by the 45-pF padder in series with the local oscillator link.

Another very important characteristic of the double-balanced mixer is reduction of spurious mixer products which often result in birdies. If, for example, you were to compare the spurious mixing products from the first six harmonics in a standard single-diode modulator, you would find no less than twenty-six separate spurious internal signals that could (and would) cause birdies. The standard series two-diode mixer that is often used in amateur equipment helps some—it only generates eleven spurious signals. The double-balanced mixer only generates five.

Although sheer numbers of internal spurious signals provide a certain guideline,

**fig. 5.** Since the currents which pass through the transformers of the double-balanced mixers are 180° out of phase, they cancel out. The output waveform is shown in B.

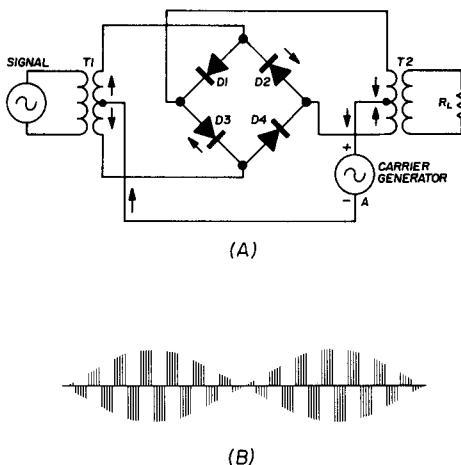

what is more important is their magnitude. In both the single-diode and series two-diode mixers, there are first magnitude signals that can cause birdy problems. In the double-balanced mixer the strongest spurious signal is of the third order.

Another application for the double-balanced mixer is the 144-MHz converter shown in **fig. 4**. If you break this circuit down into its individual parts, it's not much different from **fig. 3**. Although different transistors are used, the main differences are in the tuned-circuit values. Similar converters could be built for any of the amateur bands from 160 meters through 432 MHz or so, depending on the frequency characteristics of the unit you are using.

Double-balanced mixers are also highly desirable in the frequency-converter stages of single-sideband transmitters. Their high dynamic range, carrier suppression characteristics and low spurious output provide clean ssb signals. Also, third-order intermodulation distortion products are typically suppressed by more than 50 dB.

## theory of operation

Before we discuss any further applications of the double-balanced modulator, it might be interesting to find out how the thing really works. Consider the circuit of **fig. 5** with the signal voltage disconnected; with only the output of the carrier generator connected to the double-balanced mixer, there is no output across the load resistor  $R_L$ . When the A side of the carrier generator is negative, current flows through T1, diodes D1 and D4, transformers T2 and back to the generator as shown by the arrows. Since the currents on each side of center tap are 180° out of phase, they cancel, and there is no output. When point A is positive, current flows through T1, diodes D2 and D3, and transformer T2, again with no output.

If a signal is applied to the primary of T1, the currents in each half of the secondary are unbalanced, and an output voltage appears across the load resistor  $R_L$ . In actuality, the carrier generator switches the signal voltage on and off—nearly rectangular pulses controlled by signal amplitude are found across the load resistor at the output. To obtain

good switching efficiency and maintain minimum distortion, the frequency of the carrier signal is usually many times greater than the frequency of the signal at the rf terminals.

With a properly designed and constructed double-balanced mixer, carrier suppression on the order of 40 dB is not difficult to obtain. With this type of mixer, third-order distortion products are typically suppressed by 50 dB. Since the even harmonics are inherently suppressed by the operation of the circuit, the only spurious signals we have to contend with are those created by odd-numbered harmonics. In other types of mixers we have to contend with even-numbered harmonics as well.

An interesting modification to the basic double-balanced mixer circuit may be obtained by exchanging the carrier and signal generators as shown in **fig. 6**. In this case, when the carrier is positive on the upper side of the input transformer T1, the signal passes through the upper half of T2. When the carrier goes negative, the signal passes through the lower half of T2. The output waveform with these connections is exactly the same as shown in **fig. 5B**, with the signal current being switched back and forth through the output transformer by the carrier.

There are several advantages to be gained when the double-balanced mixer is operated in this manner. First of all, in many presently available commercial units, the input transformer T1 cannot be used efficiently below about 500 kHz. If only the standard connection shown in **fig. 5A** were available, this would limit the unit's use as a sideband generator since our signal is an audio voltage.

**fig. 6. Alternate connection to the double-balanced mixer. The output waveform is the same as shown in fig. 5B.**

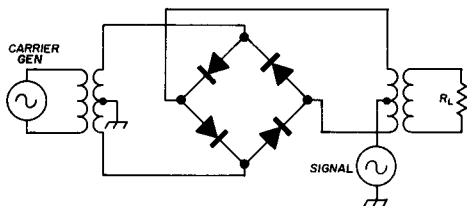

Since the carrier input is typically characterized with a dc to 200 or 300 MHz bandwidth, it is perfectly suitable for audio or video inputs. (Has anybody tried ssb for ATV video transmission?) With the alternate connection, the audio driver may be single ended. Also, it eliminates the need for balancing capacitors across the input transformer that are needed in other circuits.

**fig. 7. A 455-kHz ssb generator using the double-balanced mixer. With proper shielding and grounding, carrier suppression of this circuit will exceed 50 dB.**

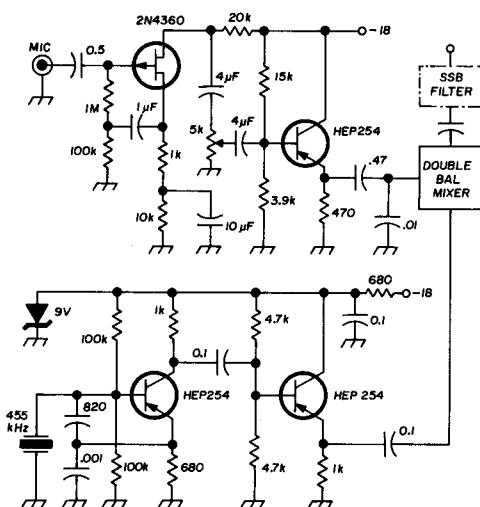

## sideband generator

One of the most appropriate applications for the double-balanced mixer is in a sideband generator. This is where it really shines. There are no touchy controls to adjust and no power connections. Just connect local-oscillator power, audio and presto—double sideband! With the filter across the output to remove one of the sidebands, you have a clean single-sideband signal with excellent carrier suppression.

At the input side of the filter, with good construction, grounding and shielding, carrier suppression of the double-sideband signal will be on the order of 40 dB. With the additional suppression afforded by the sharp skirts of the filter, carrier suppression of the ssb signal should be well in excess of 50 dB.



**VHF Specialist K9AAJ**  
—1st US/OSCAR QSO

Now... from the  
antenna specialists for  
the VHF specialists:  
the complete line of  
incomparable



**VHF Specialist W3MFY**  
—1967 VHF/SS leader

# J-BEAMS

The hottest VHF antennas are the J-Beams. A scan across the bands and through international record books proves this.

Now, Antenna Specialists makes it easy for every VHF specialist to own the J-Beam which best

fits his bands and budget. A/S took the hard part out of owning a J-Beam by importing them from England in quantity and stocking them at amateur equipment dealers across the nation. No more waiting—your dealer has 'em now!

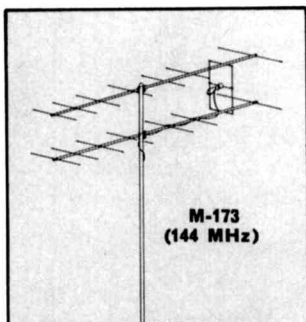

**M-173**  
(144 MHz)

For the ultimate commercial VHF radiator, pick one of the classic "8-over-8" types. There's the 144 MHz M-173, like the one K9AAJ used to score the first US/OSCAR contact. And the 432 MHz M-174, like the one used by W3MFY in his record-setting 1967 VHF Sweepstakes score.

If space or pricetag bother you, take a look at the "4-over-4" M-172 for 2 meters—it's just a few db below the bigger M-173, and makes even "lunch-box" rigs into long-haul communications tools.

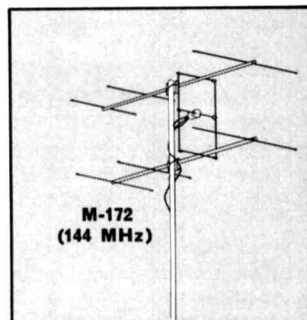

**M-172**  
(144 MHz)

Six meter specialists will delight in the M-171, with its big eight elements and nearly 25-foot boom. For those who don't need its wide capabilities, there's the four-element M-170, with more than half the M-171's gain in less than half the space!

For more information, stop by your local Antenna Specialists distributor, or write direct for your copy of the new "Amateur Communications Antennas" catalog illustrating nearly 60 antennas and antenna accessories for base station and mobile applications.

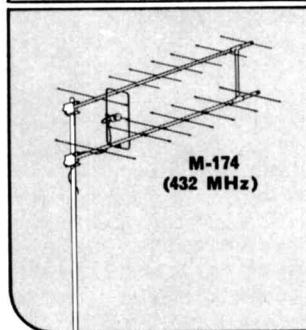

**M-174**  
(432 MHz)

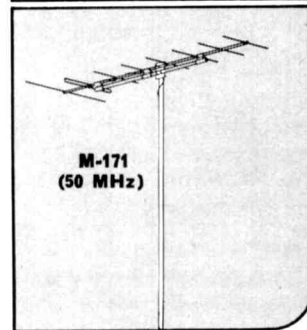

**M-171**  
(50 MHz)



**the antenna specialists co.**

Div. Anzac Industries, Inc.

12435 Euclid Ave., Cleveland, Ohio 44106

Export: 64-14 Woodside Ave.  
Woodside, N. Y. 11377



Stripes of Quality®

A ssb generator circuit using a double-balanced mixer is shown in **fig. 7**. This circuit is straight forward, small and performs very well. It could easily be built on a small printed-circuit board two inches square. By adding another crystal in the local oscillator circuit with a switch, selectable sideband would be possible at little extra cost. For proper operation, the local oscillator should provide about 10 mW of power at the local-oscillator terminals (2 V p-p into 50 ohms).

**fig. 8.** A product detector incorporating a double-balanced mixer may be added to most receivers.

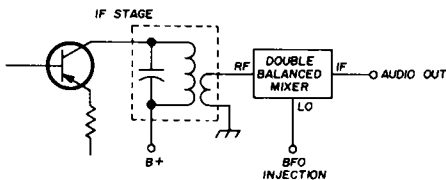

For maximum linearity, the audio signal should not exceed 1 mW or 225 mW rms.

## product detector

Another application for the double-balanced mixer is as a product detector. Although there is no significant advantage to using a double-balanced mixer as a product detector, it is an interesting application for the device. The product detector circuit shown in **fig. 8** requires a minimum of components, but does an excellent job. It has very high dynamic range and does not overload with large input signals. The local oscillator power should be from 5 to 10 mW, and the rf signal, about 1 mW.

## voltage-variable attenuator

Here is a very useful job for the double-balanced mixer. As an attenuator, it may be used with signal generators, in the input to your receiver, or as a handy gadget around the shop. All that you need is a variable source of control voltage from zero up to about 1 volt, either positive or negative. As the voltage is varied, the attenuation through the double-balanced mixer will vary from 2 to 40 dB. Make sure that the input current to the device does not exceed 60 mA. More current

than this will irreparably damage the diodes. The easiest way to limit the current is to put four series-connected forward-biased silicon diodes across the voltage source. They will limit the input voltage to approximately one volt; the 60 mA point will be above this.

## summary

These applications are just typical of the many things that can be done with these new double-balanced modulators. In addition, of course, they may be used in a-m and pulse modulators, spectrum generators and phase detectors. If you have considered building a frequency synthesizer or a phase-locked re-

**fig. 9.** This voltage-variable attenuator will attenuate the input signal from 2 to 40 dB as the control voltage is varied from zero to 1 volt. The input current should be held below 60 mA to prevent damage to the double-balanced modulator.

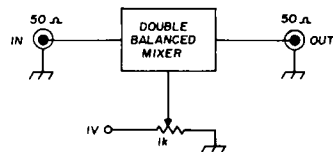

ceiver, the double-balanced modulator phase detector is an ideal choice.

For circuits that use transistors and integrated circuits, the small size of the double-balanced mixer is ideal. When you go to buy one, they may seem a little expensive, but in terms of carrier suppression, dynamic range and spurious outputs, their performance is pretty hard to beat.

ham radio

## references

1. H. D. Hooton, W6TYH, **Single Side-Band**, Editors and Engineers, Indiana, 1967, pp. 28-32.
2. E. Chicken, G3BIK, "Bridge Modulators," **RSGB Bulletin**, vol. 41, pp. 305-308, May 1965.
3. E. W. Pappenfus, W. B. Bruene, E. O. Schoenike, **Single Sideband Principles and Circuits**, McGraw-Hill, New York, 1964, pp. 44-61.
4. D. Stoner, W6TNS, **New Sideband Handbook**, Cowan, New York, 1958, pp. 31-35.
5. N. F. Moody, "A Silicon Junction Diode Modulator," **Electronic Engineer**, vol. 28, March 1956.
6. B. Goodman, W1DX, "Diode Modulators," **QST**, vol. 37, pp. 39-42, April 1953.



# Introducing



a **new** monthly  
for amateurs

that's **different** \*

- the latest in technical ideas and home construction . . .
- featuring **Jim Fisk**, W1D7Y, the well known amateur radio editor . . .
- and including articles by your favorite authors.

## how different? → \*

It looks different — it is different! It's easier to find information . . . easier to read . . . easier to understand . . . easier to build from . . . it's a magazine you'll find it easy to like.

Write for **FREE** copy . . . or

**FREE** copy and 4 month trial for \$1.00

**FREE** copy and 11 month trial for \$3.00

to Ham Radio Magazine, Greenville, New Hampshire 03048. Offer expires March 31, 1968. Be sure to include your address and Zip code.

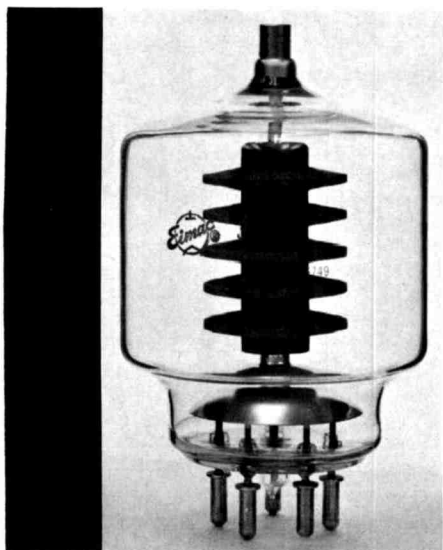

the  
**3-500Z**  
in  
**amateur service**

Here's a  
new zero-bias triode from  
Eimac that features  
increased plate  
dissipation

William I. Orr W6SAI, Eimac Division of Varian, San Carlos, California 94070 ■

The 3-500Z is a heavy-duty power triode of 500 watts plate dissipation. It is exceptionally well suited for use as a class-B amplifier in rf or audio application. It may be used in zero-bias linear-amplifier service at plate potentials up to 3000 volts, eliminating bulky and expensive screen and bias power supplies.

Of particular interest to the radio amateur is the use of the 3-500Z as a grounded-grid (cathode-driven) amplifier for ssb service. One 3-500Z is capable of a PEP input of over 1100 watts, requiring only 30 watts PEP drive power. Intermodulation distortion products at this power level are 30 dB or more below one tone of a two-tone test signal. At 2000 volts, moreover, over 500 watts of power output are obtainable with distortion products better than 38 dB below one tone of a two-tone signal. Typical operating characteristics for the 3-500Z are listed in **table 1**. A data sheet covering operation of the 3-500Z may be obtained at no cost by writing to me.

In cases requiring additional plate dissipation, the 3-500Z may replace the 3-400Z. The forced-air requirements for the two tubes are approximately equal, and a blower capable of 13 cubic feet per minute at a back

pressure of 0.2 inch is satisfactory for a single 3-500Z. (Use blower size #3 at 1600 rpm. For two 3-500Z's, use blower size #3 at 3100 rpm, or size #2½ at 6000 rpm.)

The zero-signal plate current of the 3-500Z is somewhat higher than that of the 3-400Z. When the 3-500Z is used to replace the 3-400Z, a means of reducing the zero-signal plate current is recommended, particularly if the equipment is power-supply limited. Only a few volts of bias from a low impedance source are required. The simplest way of obtaining well-regulated bias voltage is to place a zener diode in the filament return circuit of the 3-500Z (fig. 1).

The 1N4551 zener diode has a nominal voltage drop of 4.7 volts and an impedance

heat sink. Additional VOX-selective bias may be placed in series with this zener diode to reduce standby current of the 3-500Z to nearly zero in order to eliminate "diode noise" during reception and conserve standby power (fig. 2).

### the grid-current meter

It is advisable to monitor the grid current of the 3-500Z as an indicator of correct drive and antenna loading. Too much grid current indicates underloading or overdriving and too little grid current indicates underdriving or overloading, other things being equal. As the grid must be held at rf ground, the grid meter must be introduced in such a manner as not to disrupt this circuit. A simple grid

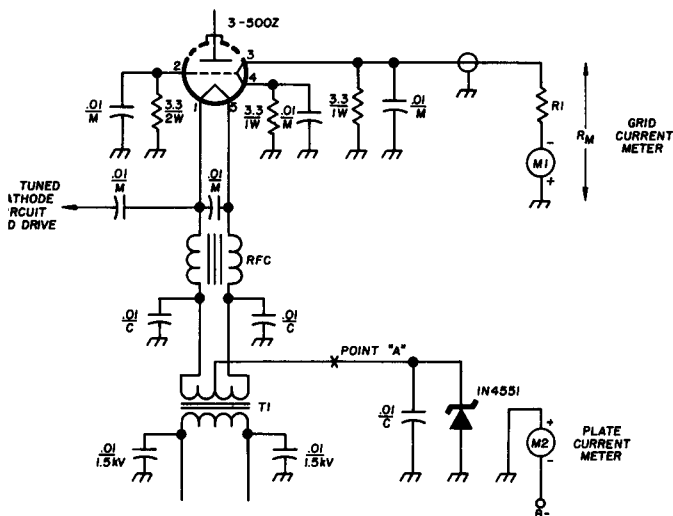

fig. 1. Zener diode bias circuit for the 3-500Z. A 1N4551, 4.7-volt, 50-watt zener diode provides cathode bias for the 3-500Z. Meter M1 (0-1 mA dc) reads grid current of the tube in terms of the voltage drop across the three grid resistors. Meter M2 reads plate current. The multiplier resistor plus internal resistance of meter M1 should total 220 ohms. Grid and filament bypass capacitors are 600-volt mica units (M). Other bypass capacitors are ceramic discs.

of 0.1 ohm, making it ideal for this service. At this value of bias, the zero-signal plate current of the 3-500Z at a plate potential of 3250 volts is reduced from 160 to approximately 90 milliamperes.

The zener diode may be bolted directly to a cool area of the chassis which will act as a

meter scheme is shown in fig. 1. Each grid pin is grounded through a .01- $\mu$ F mica capacitor paralleled with a 3.3-ohm, 2-watt composition resistor. A small dc voltage drop exists across the resistor under normal tube operation. The voltage drop is read by a simple dc voltmeter (M1) calibrated in terms of grid current.

In the example shown, it is desirable that the grid meter have a full-scale indication of 200 milliamperes. The dc grid-to-ground resistance is about 1.1 ohm, and, at a current of 200 mA, a voltage drop of 0.22 volts will be developed. The 0-1 dc milliammeter is converted to read 0.22 volts full scale by the inclusion of a series multiplier resistor. The sum

table 1. Typical operation of the 3-500Z in grounded-grid rf linear-amplifier service.

|                                      |      |      |      |      |
|--------------------------------------|------|------|------|------|
| DC plate voltage                     | 3000 | 2500 | 2000 | V    |
| Zero-signal dc plate current         | 160  | 130  | 95   | mA   |
| Single-tone dc plate current         | 370  | 400  | 400  | mA   |
| Single-tone dc grid current          | 115  | 120  | 130  | mA   |
| PEP input power                      | 1110 | 1000 | 800  | W    |
| PEP useful output power              | 750  | 600  | 500  | W    |
| Resonant load impedance              | 5000 | 3450 | 2750 | ohms |
| Cathode input impedance              | 115  | 100  | 100  | ohms |
| Intermodulation products (3rd order) | -30  | -33  | -38  | dB   |

fig. 2. VOX-selective cutoff bias circuit. Additional cutoff cathode bias is added by the VOX relay to reduce standby plate current to near-zero, eliminating "diode noise" in a nearby receiver. The bias is added at point A in fig. 1.

of the resistor plus the meter resistance should total 220 ohms.

### 3-500Z circuitry

No specific circuits are shown for the 3-500Z, since published 3-400Z circuitry applies equally well to this tube. Two 3-500Z's may be used in place of a single 3-1000Z with

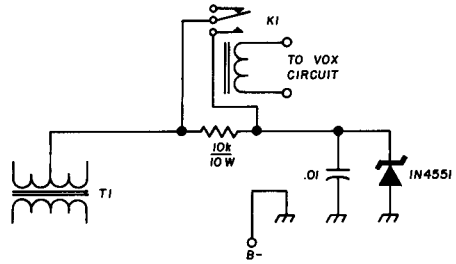

appropriate corrections in air flow, filament power requirements and zener bias (if necessary).

ham radio

## rf generator clip

Connecting an rf generator to a piece of equipment for test purposes can sometimes pose a problem. Many times a simple expedient is used: a couple of test leads with alligator clips. In most cases this is not too satisfactory. First, there is no isolation between stages, because the leads are usually quite long and radiate heavily. Besides, it is pretty unhandy.

The generator clip described here is based on a BNC connector because all the test gear in my shop uses them. Although a UG-89B/U was used in this case, a UG-23/U, PL-259 or an Amphenol audio connector could be adapted in just about the same way. To insure that the generator is terminated in a 50-ohm load (or thereabouts), a 1/2-watt, 5%, 51-ohm resistor is mounted inside the coaxial connector. One lead of this load resistor is soldered to the female pin of the connector.

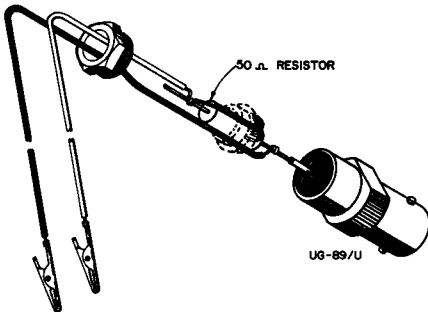

Exploded view of the diode mount. The two connector nuts and button capacitor are soldered into one unit. The method of bending the capacitor tabs is also shown.

A short length of flexible test-prod wire with an alligator clip is also soldered at this point.

The other end of the resistor is connected to the ground side of the test circuit. This is done by stripping the insulation off another piece of test-prod wire about one inch back from the end. The resistor is soldered to the wire up next to the insulation, and the wire strands are brought down around the body of the resistor. The braid-retaining washer from the coaxial connector is then put over these wire strands and the body of the resistor; the strands are bent over the shoulder of this washer. When the cable nut is tightened into the connector body, these strands will ground the test lead and hold the test wires and resistor in the connector.

To protect the assembly and to prevent the test leads from breaking at the solder points, a short length of heat-shrinkable tubing is placed over the unit and shrunk into place. After it's all put together, check with an ohmmeter to make sure the two test leads are not shorted; they should exhibit 50-ohms resistance.

Some amateurs might like to place a coupling capacitor within the connector. There is room for a small 50- or 100-pF ceramic tubular capacitor if a 1/4-watt load resistor is used. In some cases you might want to delete the terminating resistor. In any event, this little clip provides a very simple and convenient way of getting rf energy from the generator into a circuit.

Jim Fisk W1DTY



## If the DAVCO DR-30 is only the finest amateur receiver made, why have so many professional users bought DR-30's?

By now, most hams know that the DAVCO DR-30 is one of the most versatile ham-band receivers ever manufactured. They know that the DR-30 is a rugged, compact, solid-state communications receiver covering all the ham bands from 3.5-50.5 MHz with exceptional performance and almost every feature any ham has ever desired. But they may not realize that people other than amateurs have also recognized the excellence of the DR-30 for other uses. Commercial, scientific and government users have bought DR-30's for applications ranging from wolverine tracking to short-wave monitoring, from radio astronomy to receiving WWV. Obviously, the requirements for these varied applications differ widely; only a receiver with the versatility of the DR-30 could satisfy them all. Professional users have discovered that the characteristics that make the DR-30 ideal for any type of ham receiving application also make it perfect for other uses. They value the DR-30 for its ruggedness, reliability, modular construction, exceptional sensitivity, resistance to overloading, stability, choice of modes and bandwidths, excellent noise blanker, wide frequency coverage, low power consumption, convenient compactness, protection from incorrect polarity, low spurious responses, accurate frequency calibration, complete detailed manual and reasonable price (\$389.50).

These users know the versatility of the DR-30. If the DR-30 excels in so many exacting professional applications, imagine how it would perform in your shack!

We would like to tell you more about the DR-30. Drop us your card for our complete data pack. It includes an eight-page technical brochure, a large schematic and reprints of reviews of the DR-30 from QST, CQ, and 73. If you would like even more information, the 48-page DR-30 Instruction Book is available for \$2.00 (which will be refunded with your DR-30 order, of course).

Here is a partial list of DAVCO professional customers:

Division of Biological & Medical Research,  
Argonne National Laboratories  
Research School of Physical Science, Australian National University  
Ball Brothers Research Corporation, Wildlife Research Center  
Bureau of Sport, Fisheries & Wildlife  
Canadian Department of National Defense  
Collins Radio Company  
Consulate General of Israel  
Radio Free Europe  
Lehigh University  
Canadian National Research Council

Naval Research Laboratory  
Oregon State Game Commission  
Oregon State University  
Pennsylvania State Game Commission  
Tufts University  
Underwater Sound Laboratory, New London, Connecticut  
University of California  
University of Hawaii  
University of Illinois  
University of Texas  
U. S. Naval Ordnance  
U. S. Naval Submarine Base  
Zenith Radio Research

ATTENTION short-wave broadcast monitors and serious SWL's: The DAVCO DR-50 Professional Short-Wave Broadcast Receiver provides the ultimate in no-compromise reception for the most demanding applications. It is available now from stock. Write for complete information.

# DAVCO ELECTRONICS, INC.

P. O. Box 2677

2024 S. Monroe Street

Tallahassee, Florida 32304

# Engineering Technicians

**You will do better at Sanders  
because you will join a systems team  
where you have an  
opportunity to learn more**

Would you like to team up with engineers on significant systems problems? If you are an Electronic, Mechanical, Test Equipment or Calibration and Standards Technician here is your opportunity.

Sanders is a systems company. Here you will be working on unique new defense, space, oceanographic, data handling and communications systems. In fact, you will find that systems are everyone's business at Sanders. More than 90 per cent of our business comes from systems, programs and hardware we developed ourselves. And, the growth has been rapid. Last year sales doubled, growing from 66 to over 139 million dollars.

And there is the opportunity and security that only such growth can give. New positions and new opportunities are opening daily. And you will find that Sanders does not hire people just for the duration

of one program or one project. These are permanent, well paying positions where you can develop your full career potential.

We try to help. Sanders has an in-plant college degree program as well as a 100 per cent pre-paid tuition plan for outside study. Other benefits include excellent starting salaries, a merit review program, a liberal paid vacation-holiday program and comprehensive Life, Medical, Surgical and Hospital benefits for you and your family.

**WRITE** or send your resume to Mr. Sherrill Spencer at Sanders Associates, Inc., Dept. 181HR, Nashua, N.H. today or telephone him at (603) 889-6631 (collect) to arrange an interview if you have a solid technical school or military background and a real interest in a systems career.

CREATING NEW DIRECTIONS IN ELECTRONICS



\* T. M. SANDERS ASSOCIATES, INC. An Equal Opportunity Employer M/F

The pre-con, ready to go to work! When used with a grid-dip oscillator, this instrument is very handy in measuring unknown coil values. It is also invaluable as a variable capacitor substitute when designing rf tank circuits.

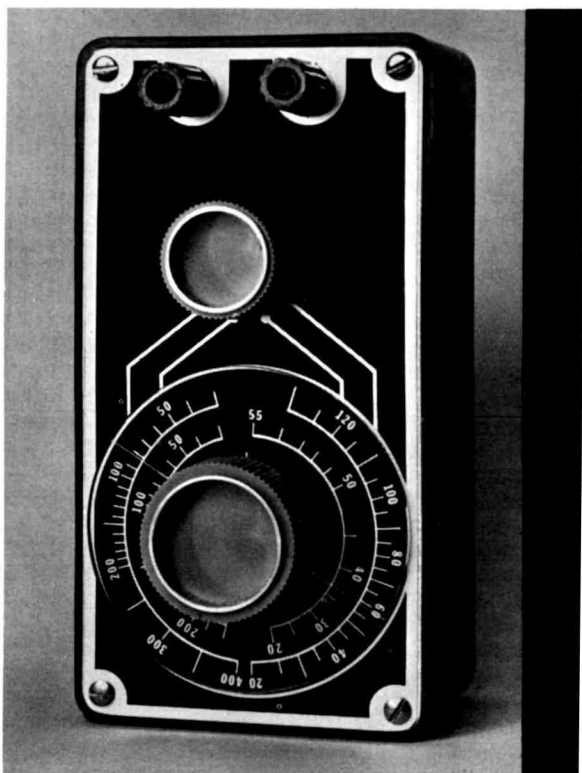

## pre-con

A low cost  
semi-precision  
capacitor of  
simple  
construction

E. L. Klein W4BRS, 6814 Criner Road  
S. E., Huntsville, Alabama 35802

The ham-radio experimenter frequently finds himself in need of a variable capacitor—one which is calibrated to a fairly accurate degree so as to be called a semi-precision capacitance standard. This need was recently experienced when building toroid tank coils for amateur applications.

Very few hams have access to a Q-meter, an instrument which is ideal for proving calibrations and verifying coil construction. But most all shacks have a grid-dipper. Now, by adding the **pre-con** to our collection of most used instruments, we are able to measure unknown coils and capacitors with ease.\*

\*J. Fisk W1DTY, "A Semi-Precision Capacitor", 73 Magazine, February 1967.

## component parts

The accuracy of a precision capacitor is directly related to the quality of its component parts, as well as the quality of workmanship which goes into its construction. However, if our calibrated capacitor is to be used in conjunction with a grid dipper, we might reason that the capacitor's accuracy need not be significantly greater than that of the grid-dip meter.

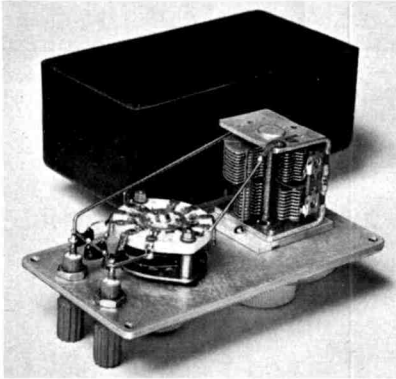

Construction of the capacitance standard is simple and straight forward. All components are mounted on the aluminum front panel. Copper bus wire (#16 AWG) is used because of its rigidity for making interconnections.

Therefore, a common midget-radio broadcast-tuning capacitor was selected as the main tuning element. These are available from Lafayette for as little as 39c. All variable mica trimmers should be removed and discarded. The unit pictured here was a junker, but did have the added advantage of a planetary vernier drive built into its 1/4-inch diameter control shaft. This proved to be most convenient. It permitted the scribed pointer to be fastened to the direct-drive portion of the shaft while the knob was fastened to the high-speed end.

The time proven device of inserting a fixed capacitor in series with the tuning capacitor is employed to obtain electrical band spread. This in effect makes it appear that a smaller tuning capacitor was being used, and thence a lower range. Three different capacitors having the values of 510, 180 and 47 pF provided three suitable ranges on the author's pre-con as shown in fig. 1.

The dial pointer is made from 1/8-inch thick lucite. A 2 3/4-inch diameter fly-cutter is used to cut halfway into the lucite from each side. Its cutting bit should be reversed so that a straight-sided cut is made around the periphery of the pointer. A hairline is made by scratching into the underside of the lucite. India ink, carefully ruled into the scratch, will provide a permanent, sharp black hairline.

## construction

A small bakelite instrument box was used for the housing of the unit shown in the photographs. These are available from

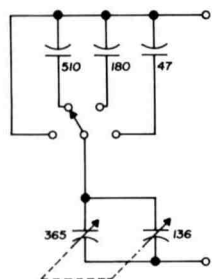
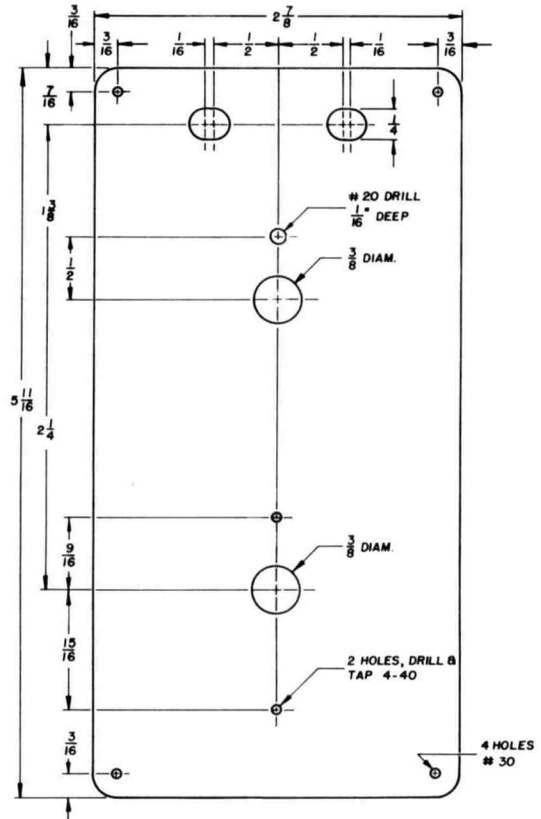

fig. 1. Schematic of the semi-precision capacitor. Dipped silver-mica capacitors are used for the three series capacitors mounted on the switch. A midget broadcast tuning capacitor provides better than 400 pF maximum capacitance.

fig. 2. Panel for the precision capacitor is made from 1/8-inch aluminum. Thinner material, such as 1/16 inch, may be used with some sacrifice in rigidity.





several surplus houses. The reader might have shared our surprise in having seen their cost recently rise from 59c to 95c to \$1.59. An aluminum mini-box may be the better bet because it provides a ready-made panel, as well as affording shielding around the capacitor. If the plastic box is used, its panel should be cut from  $\frac{1}{8}$ -inch thick aluminum in the interest of rigidity. The vital panel dimensions for the **pre-con** are shown in fig. 2.

In the interest of minimizing hand capacitance, the tuning capacitor is insulated from the panel, and the panel is left as a floating shield. If a totally enclosed metal housing is used, it could be secured to the capacitor frame. Fig. 3 is a drawing of an insulating mounting bracket which is used to hold the tuning capacitor away from the panel. After wiring up the **pre-con** with stiff #16 AWG

copper bus wire, the instrument is ready for calibration.

### calibration

Each different instrument must be separately calibrated. This is particularly true when you use available tuning capacitors and other odd parts. The full-scale pattern shown in fig. 4 illustrates a typical panel design. The constructor should check his instrument against another known standard. Placement of the individual dial-calibration points may then be verified.

The first step in calibrating the **pre-con** is to cement a piece of bond paper onto the panel face. Rubber cement works best because it can be readily peeled off later. With the dial pointer and knob installed, the maximum values for each of the four ranges are measured and recorded on a separate piece of paper. Knowing the limits of each range, we can then decide what major scale divisions will be used on the dial.

I had temporary access to a precision General Radio capacitance bridge which made calibration a breeze. Lacking this fine equipment, the amateur constructor should purchase a few 10-, 50-, and 100-pF silvermica capacitors of the closest tolerance (5% or better) that he can afford. If a capacitor checker such as made by Heathkit is available, these capacitors will serve to double check the accuracy of its dial. If only a grid dipper

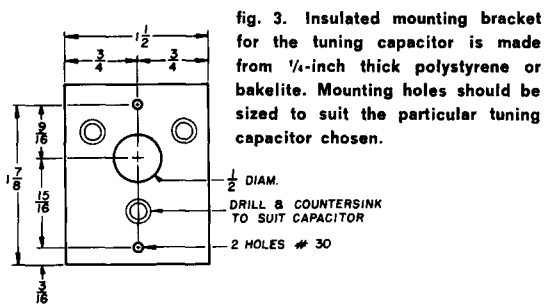
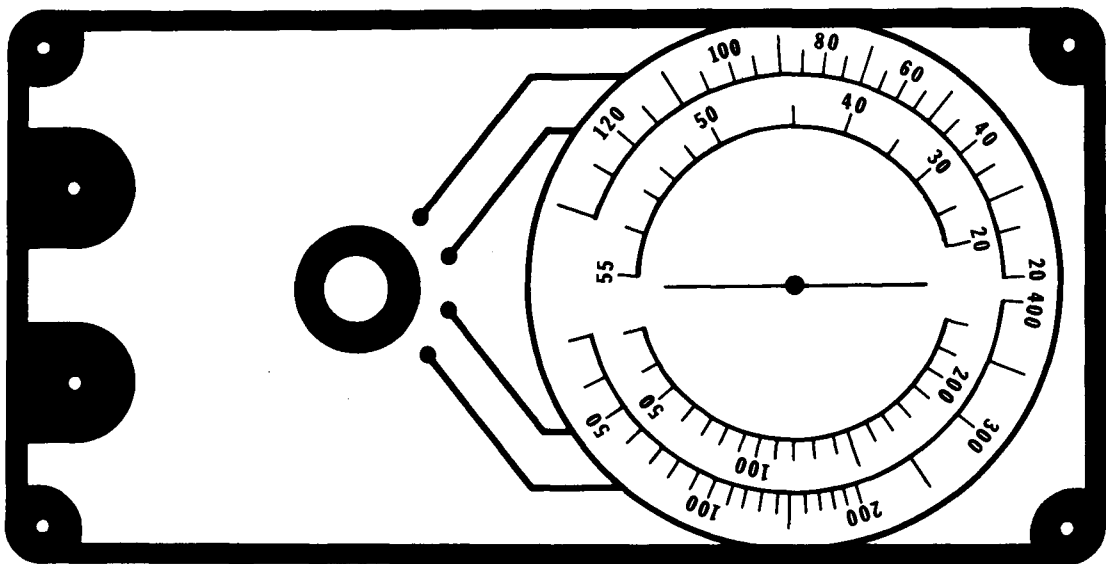

fig. 3. Insulated mounting bracket for the tuning capacitor is made from  $\frac{1}{4}$ -inch thick polystyrene or bakelite. Mounting holes should be sized to suit the particular tuning capacitor chosen.

fig. 4. Full-scale pattern of the panel name plate. Drawing may be made with pen and ink and mounted on the panel with epoxy cement or it may be photo-engraved into the aluminum itself.



# DIPLOMAT COMMUNICATIONS DESK



The above picture shows the R. L. Drake factory display at Miamisburg, Ohio, featuring the famous "Drake Line" on a Diplomat Communications Desk.

## EMPLOYS ALL OF THE DESIRABLE FEATURES FOR CONVENIENT OPERATION

Send for brochure on this and other models, priced from \$79.95 to \$495.00.

### SOLD THROUGH THE FOLLOWING AUTHORIZED DISTRIBUTORS

- AMATEUR ELECTRONIC SUPPLY Milwaukee, Wisconsin
- AMRAD SUPPLY, Inc. San Francisco, Calif.
- C. W. ELECTRONICS Denver, Colo.
- ELECTRONICS CENTER, INC. Dallas, Texas
- HARRISON RADIO CORP. New York
- HATRY OF HARTFORD Hartford, Conn.
- HENRY RADIO CO., INC. Los Angeles, Calif.
- MOORY'S WHOLESALE RADIO DeWitt, Arkansas
- PURCHASE RADIO SUPPLY Ann Arbor, Michigan
- SREPCO ELECTRONICS Dayton, Ohio
- UNCLE GEORGE'S RADIO HAM SHACK Wheaton, Maryland
- WORLD RADIO LABS, INC. Council Bluffs, Iowa

## DESIGN INDUSTRIES, INC.

P. O. Box 19406

● PHONE 214-528-0150 ●

DALLAS, TEXAS 75219

table 1. Material required for the pre-con.

- 1 Bakelite instrument box, 3" x 6" x 2 1/2" (Lafayette)
- 1 Panel, 2 1/4" x 5-11/16" x 1/8" aluminum
- 1 Capacitor, miniature BC (Lafayette)
- 3 Dipped mica capacitors, 510, 180, 47 pF
- 1 Wafer switch, SP4T (Mallory)
- 2 Terminal posts
- 2 Knobs

is on hand, it may be used in conjunction with an arbitrary coil to cross-check between your fixed capacitors and your **pre-con**.

As each major scale calibration point is determined, a pencil mark is made on the temporary bond-paper panel face at the outer edge of the pointer. Different colored pencils are recommended to avoid confusion between the several ranges. Having identified the major dial markings, the intermediate points may be established by interpolation. A careful eye and steady hand will produce a nice-looking job.

### making the panel face

Dial calibration points may be permanently marked on the aluminum panel in a number

of ways. India ink will take well on aluminum which has been given a satin finish with Drano or some other caustic. The builder may desire to transcribe his markings in ink onto a fresh piece of bond paper and cement it to the panel. In either case, it is a good idea to spray the finished markings with a clear plastic coat. The panel face illustrated in this article was photoengraved on pre-sensitized and blackened aluminum stock.

### using the pre-con

Principle use of this calibrated capacitor will be found in designing rf tank circuits. Of course, its degree of accuracy will in no way match that of the semi-precision capacitor described recently by Jim Fisk. However, when used with a grid dipper, it is most convenient in determining the number of turns required to resonate an experimental coil at a proper frequency and in the correct band. I have found the **pre-con** to be very valuable at W4BRS, and its ease of construction should make it an interesting week-end construction project for many amateurs.

ham radio



When hams discuss  
 discuss  
**OPTIMUM  
 SPACING'**  
 in single  
 band beams . . .

. . . . . *The subject turns to **Mosley***

Amateurs punch through the QRM on 20 meters with Mosley's A-203-C, an optimum spaced 20 meter antenna designed for full power. The outstanding, maximum gain performance excels most four to six element arrays. This clean-line rugged beam incorporates a special type of element design that virtually eliminates element flutter and boom vibration. Wide spaced; gamma matched for 52 ohm line with a boom length of 24 feet and elements of 37 feet. Turning radius is 22 feet. Assembled weight - 40 lbs.

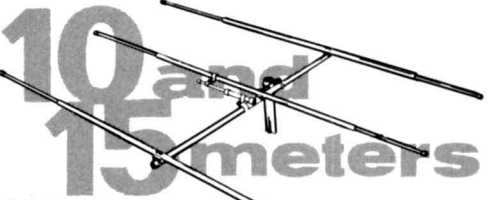
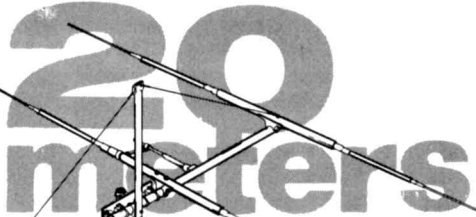

A-310-C for 10 meters  
 A-315-C for 15 meters  
 Full sized, full power, full spaced 3-element arrays. 100% rustproof all stainless steel hardware; low SWR over entire bandwidth; Max. Gain; Gamma matched for 52 ohm line.

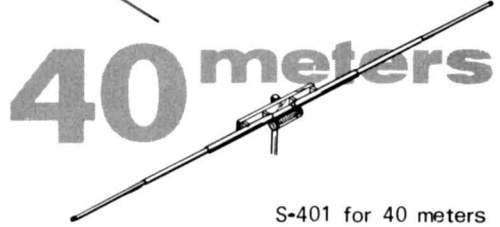

S-401 for 40 meters  
 Full powered rotary dipole. Top signal for DX performance. 100% rustproof hardware. Low SWR. Heavy duty construction. Link coupling results in excellent match. Length is 43' 5 3/8"; Assembled weight - 25 lbs.

For detailed specifications and performance data, write Dept 157.  
**Mosley Electronics, Inc.** 4610 N. Lindbergh Blvd., Bridgeton, Mo. 63042



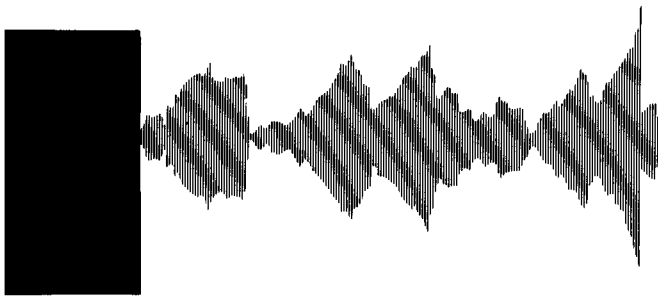

a

**beginner's**

**guide to**

## **single sideband**

A candid  
look at what makes  
single sideband  
tick

Forest H. Belt, 119 Baker Avenue, South Plainfield, N. J. 07080

There's been plenty of discussion during the past few years about the rag-chewers' migration to a form of voice transmission that is growing in popularity. The "new" mode—called **single sideband** or just **ssb**—has for many hams largely supplanted the older **amplitude modulation** or **a-m**. Fans of ssb claim superior communication.

Single sideband isn't really new. It's been around since long before World War 2. Telephone and military uses of single sideband antedate its use for amateur radio by several years. Expense was what finally brought it up to date. Once crystals and other parts became available at reasonable cost, and more efficient circuits were designed, single sideband moved into the price range a radio amateur could afford.

With ssb transmission popping up all over the bands, and even some old timers preferring to switch rather than fight, questions keep coming up: What is single sideband? Why is it better (or worse) than a-m? How is it done? How do you use it? You may have wondered some of these things yourself. The answers lie in the very nature of single sideband. That, then, is a good place to begin.

## what is a sideband?

There was a time when sidebands were thought of as a useless byproduct of amplitude modulation. That just isn't true. The sidebands are the most important part of the a-m signal; without them, voice transmission would be impossible. Two of them are produced by ordinary amplitude modulation—one on each side of the carrier.

To understand how they are produced, you must first understand exactly what happens

fig. 1. Modulation envelope of an a-m signal.

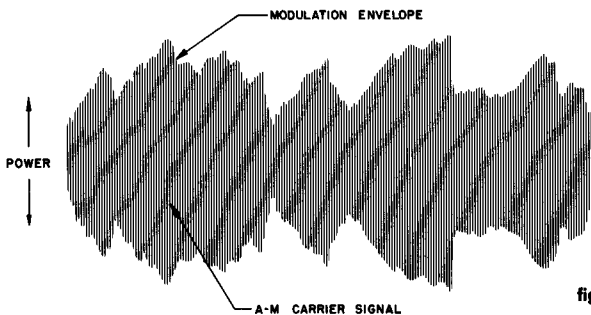

voice-varied carrier signal forms a modulation envelope that is a graph of its varying amplitude. Fig. 1 shows this modulation envelope.

2. The signals heterodyne, as any two electronic signals will do when mixed in a circuit like this. The products of heterodyning are, in addition to the original signals, their sum and their difference. The voice signal is a complex one, as you can see from the modulation envelope in fig. 1. It contains many frequencies between 100 and 3000 Hz; for easy calculation, they can be considered as one block of frequencies, called merely the **voice or audio frequencies**.

The **sum** of the carrier and voice signals is a block of signals: 14,250,000 Hz **plus** the 100-to-3000-Hz block of voice frequencies; the sum is 14,250,100 to 14,253,000 Hz. This block of sum frequencies is called the **upper sideband**, and is shown in a spectrum graph in fig. 2.

fig. 2. The upper-sideband of a signal centered on 14.25 MHz.

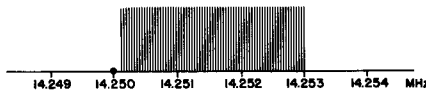

in the process called **modulation**. Reduced to simple concepts, modulation is merely the mixing of two electronic signals of different frequencies. Consider amateur-band communications, for example. One of the signals is at voice frequencies, audio signals generally between 100 and 3000 Hz. The other may be at any radio frequency assigned to ham radio. For this explanation, we'll pick one in the 20-meter band: 14.25 MHz.

Though the 14.25-MHz radio-frequency (rf) signal is called a **carrier**, it isn't really needed to "carry" anything. It is needed only in the modulator, to help form the sidebands. It will be needed again later for the demodulator in the receiver—but that's getting ahead of the story. In the transmitter modulator, the 14.25-MHz signal is merely a vehicle with which the voice signal can mix. The two are mixed in such a way that two things happen:

1. The power of the carrier signal is varied in exact step with the audio signal. This is called **amplitude** modulation because the



fig. 3. The lower sideband of a signal centered on 14.25 MHz.

The **difference** between the two signals is also a block of signals: 14,250,000 Hz **minus** the 100-to-3000-Hz block of voice frequencies; the difference is 14,249,900 to 14,247,000 Hz. This block of difference frequencies is called the **lower sideband**, shown in another spectrum graph in fig. 3.

## where the power goes

When you look at a spectrum graph of the full voice-modulated a-m signal (fig. 4), you begin to see the whole picture of what's happening with amplitude modulation. An astonishing fact is that 66% of the total rf output of the transmitter is in that carrier, and only 17% in each of the sidebands—even at full modulation. This is not by design; it is merely a result of the modulation system.

What makes it astonishing is that the

carrier is not really needed in the output. Once it has done its job of heterodyning in the modulator, it can be eliminated completely as far as transmission is concerned. The voice power is in the sidebands alone, and they are rf signals that propagate just as well as the carrier does.

This brings out why proponents of single-sideband transmission are so critical of a-m. An a-m transmitter with rf output of 750 watts puts 500 of those watts into the carrier. The 250 watts in the two sidebands (125 in each) is the only power that is really of any value to communication. As a matter of fact, you can see from **fig. 4** that either sideband is a mirror of the other, so it is actually a waste to use both sidebands. When the signal reaches a receiver, the information contained in one sideband can, correctly processed, develop just as much recovered audio as the whole double-sideband-plus-carrier signal.

The conclusion? A 125-watt single-sideband transmission can produce at least as much intelligible radio communication as a 750-watt amplitude-modulated transmission. Imagine what you can do with a full kilowatt concentrated in one sideband!

### recovering the voice signals

The only reason a carrier is needed at the receiver is for the demodulator. It isn't needed for tuning, because the receiver can be tuned to 14.25 MHz merely by reference to either group of sideband frequencies. In a conventional a-m detector, the carrier and the two sidebands are fed to a nonlinear detector: usually a diode. This causes heterodyning between the carrier and the two groups of sideband frequencies. The difference "group" comprises the original 100-to-3000-Hz voice signals.

Without the carrier, the upper and lower sidebands have nothing to heterodyne with, so the voice intelligence can't be recovered. A single-sideband signal, which is transmitted without any carrier signal, can't be demodulated in an ordinary a-m detector. The answer is to re-insert a carrier of some sort at the receiver.

Since superhets are the only practical receivers for this kind of communications, the

carrier-reinsertion problem is simplified. The rf sideband is converted to an i-f sideband. An i-f carrier—which is easier to generate accurately than a 14.25-MHz rf carrier—is added, and the two are fed to a diode detector where normal demodulation takes place.

**fig. 4.** Spectrum graph of an a-m signal showing the carrier at 14.25 MHz and the upper and lower sidebands.

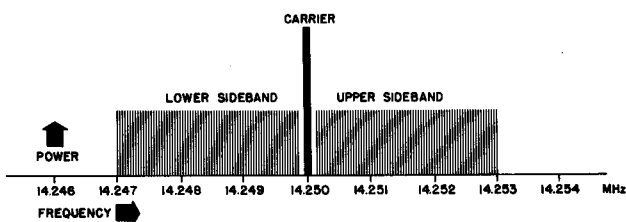

### generating an ssb signal

Now that you understand the rudiments of single-sideband communication, you probably wonder about some of the more technical details. Knowing them will help you understand ssb even better. For example, there is the question: What's a practical way to develop a single-sideband signal?

Without worrying about specific details of circuit analysis, take a look at **fig. 5** for an explanation of how a simple single-sideband transmitter generates its signal. A crystal-controlled oscillator, usually at a very low radio frequency, supplies the carrier for modulation. The oscillator frequency may range from 50 to 500 kHz, and occasionally higher. A common one for this purpose is 100 kHz.

The operator's voice is picked up by a microphone, and the voice signals are amplified by the speech amplifier. Voice frequencies below 100 Hz and above 3000 Hz are not needed for intelligible communication, so they are filtered out by circuits in the speech amp. What's left is the 100–3000-Hz block of natural voice frequencies.

Both the carrier signal and the voice signals are fed to a **balanced modulator**. There are several different kinds of circuits used for this stage, some with diodes and others with tubes or transistors. There are even special switching tubes that make excellent balanced modulators. The balanced modulator mixes

the voice and carrier signals in such a way that both sidebands are produced normally, but the carrier is balanced out. **Carrier suppression**, the process is called.

The output of a balanced modulator is technically named a **double-sideband suppressed-carrier** signal. With the 100-kHz oscillator signal and the usual block of voice frequencies (100 to 3000 Hz), the upper sideband extends from 100.1 to 103.0 kHz; the lower sideband extends from 97 to 99.9 kHz. The two sidebands are shown in the spectrum graphs in **fig. 5**. The carrier, which served its purpose in the modulator, has been elimi-

**fig. 5. Block diagram of a simple single-sideband generator.**

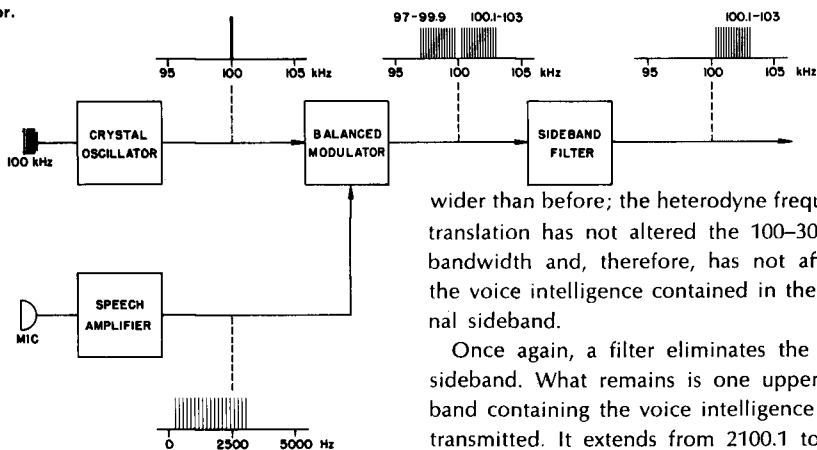

nated in the output of the balanced modulator.

It is in the next operation that the signal first becomes single-sideband. The method is deceptively simple: a filter is used which passes the desired sideband and blocks the other. In some ssb transmitters (variously called **sideband generators** and **ssb exciters**), an electromechanical filter is used. In others, a "lattice" of quartz crystals gives the filter the wideband response curve needed. You see, if the transmitter is to operate on the upper sideband, the filter must pass the frequencies 100.1 to 103 kHz, while blocking 97 to 99.9 kHz. The output of the sideband filter in **fig. 5** shows the lower sideband reduced drastically.

### the correct output frequency

Of course, the single-sideband signal at 100.1–103 kHz is not to be transmitted di-

rectly. Somehow the single-sideband voice intelligence must be translated to a frequency within the Amateur Radio Service. How about 14.25 MHz, the 20-meter ham frequency we used earlier? This is ordinarily done in two steps, both of which you can see in **fig. 6**.

The 100.1–103-kHz sideband is mixed with a 2000-kHz (2-MHz) oscillator signal. The result of their heterodyning is another pair of sidebands—one equal to the sum of the input sideband and the oscillator signal, and the other equal to their difference. Two things are apparent. The sidebands are much further apart than before, which makes them easier than ever to filter. Also, they are no

wider than before; the heterodyne frequency-translation has not altered the 100–3000-Hz bandwidth and, therefore, has not affected the voice intelligence contained in the original sideband.

Once again, a filter eliminates the lower sideband. What remains is one upper sideband containing the voice intelligence to be transmitted. It extends from 2100.1 to 2103 kHz. This sideband is ready to be raised to the transmitter output frequency. When that is done, the output signal should be a single sideband extending from 14,250.1 to 14,253 kHz. (That's the upper sideband of 14.25 MHz.)

The second frequency conversion is accomplished in another heterodyne mixer. The rf signal is supplied by a very stable variable-frequency oscillator (VFO). It is variable so the transmitter can operate at other frequencies besides the one in our example.

When the dial of the VFO indicates 14.25 MHz, the stable oscillator furnishes an rf frequency of 12,150 kHz. In the heterodyne mixer, this rf signal beats against the 2100.1–2103-kHz sideband and produces two new sidebands. One of these, the new lower sideband, is the difference heterodyne: 10,047–10,049.9 kHz. The new upper sideband is the sum: 14,250.1–14,253 kHz. The latter is exact-

ly what you need; it is the upper sideband of 14.25 MHz.

Must you have another filter to get rid of the unneeded lower sideband? Not necessary. The two sidebands are so far apart—more than 4 MHz—that one can be easily eliminated now by ordinary tuned circuits. A tank tuned to 14.25 MHz has plenty of bandwidth to include the sideband just above. Therefore, eliminating the lower sideband is no more

fig. 6. Block diagram of a single-sideband transmitter which puts the sideband signal generated in fig. 5 on 14.25 MHz.

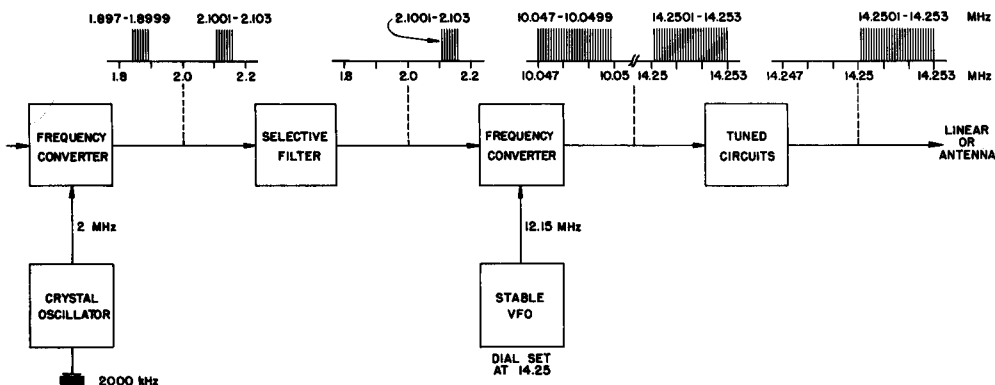

complicated than merely tuning the output of the second mixer to 14.25 MHz, the “reference” frequency for this single-sideband signal.

For any other transmitter frequencies, the VFO frequency can be reset. At the same time, the tuned tanks following the second mixer must be retuned to the new frequency. As an example, a VFO dial setting of 14.3 MHz causes an oscillator signal of 12.2 MHz. Mixed with the 2100.1–2103-kHz sideband from the second sideband filter, the 12.2-MHz signal heterodynes a new lower sideband at 10,097–10,099.9 kHz and a new upper sideband at 14,300.1–14,303 kHz. The tank circuits following the second mixer, tuned now to 14.3 MHz, eliminate all trace of the 10-MHz lower sideband. The upper one, which is the upper single-sideband signal of 14.3 MHz, is coupled on to the transmitting antenna or to whatever amplifying stages follow.

### building up single-sideband power

A complete single-sideband transmitter has another section in addition to those already

shown. The final section is the power amplifier. It includes amplification for the sideband signal, plus output coupling to feed the single-sideband signal to the antenna. In both these actions, there is only one difference between the ssb transmitter and any other: the ssb signal must be amplified without the slightest distortion. If the amplifier were nonlinear, the sideband signals would mix and beat against one another, forming an unintelligible mass of frequencies. There is no carrier to maintain a sideband relationship,

so nonlinearity in amplification just isn’t permissible.

The amplifier, then, must be linear at all cost. The final stage of a single-sideband transmitter is called just that: **linear amplifier**. It is operated class A for low power, or class AB<sub>1</sub> or AB<sub>2</sub> for high. The important thing is to make sure the stage (or stages) is adjusted so it generates no harmonics. The sideband must be reproduced intact and unchanged.

Regulation in the voltage supply furnishing dc power to the linear amplifier tubes is critical. Keep in mind that power in the sideband signal follows closely every slight rise and fall in volume of the voice producing it. In fact, when there is no voice, even for the slight instant between two spoken words, there is no power, for there is no sideband signal. This greatly and rapidly fluctuating demand on the dc power supply can be difficult to handle without adequate regulation. Sometimes regulator tubes are used, particularly in the supply that furnishes dc to the linear-amplifier screen grids. Generally, at least with low- or medium-power ssb trans-



mitters, an oversize output filter capacitor is sufficient to handle the sudden load variations.

Measuring the output power of a single-sideband transmitter is more complicated than measuring that of an a-m transmitter. The a-m transmitter produces nearly 70% of its power continuously, in the carrier. Only when a voice modulates the transmitter is the other 30% or so developed, and then only if the voice is loud enough to drive the transmitter modulator to full (100%) modulation. When typical voice modulation is analyzed, its waveforms are found to approach maximum amplitude very seldom. Thus, total output power of a normally modulated a-m transmitter rarely exceeds an average of 10% above its no-modulation power. As a consequence, a-m transmitter power is measured directly, with little concern for modulation.

The power output of a single-sideband

fig. 7. Block diagram of a double-conversion superhet receiver suitable for ssb reception.

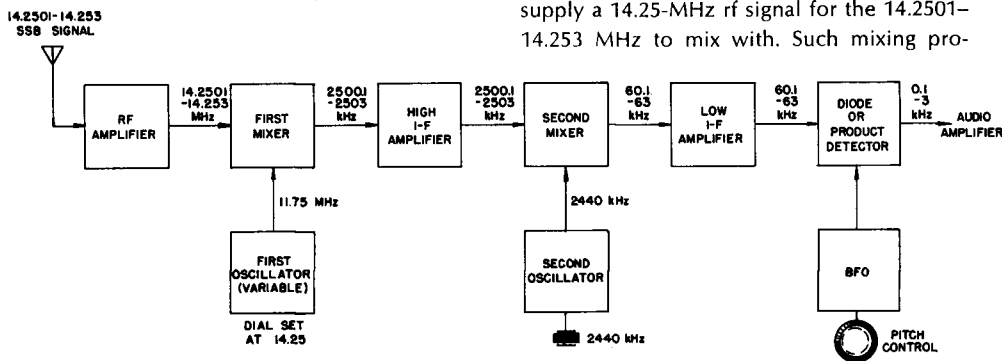

transmitter, on the other hand, depends **entirely** on the voice modulation. As you've already seen, a voice varies the output power considerably, depending on word inflections, voice loudness, even voice timbre. To account for that, power in single-sideband transmitters can best be rated by **peak envelope power (PEP)**.

Peak envelope power is not necessarily a measure of how much power an ssb transmitter is producing at any particular time, but is a measure of its power capability. The wattage figure stated in a PEP rating signifies the output rf power when the transmitter is **fully** modulated for a period of time sufficient

to make the measurement. The truth is that this almost never happens. In fact, the rating is based on a test signal of two sine-wave audio tones; continued stress to that extent can damage most ssb transmitters. Nevertheless, voice peaks do reach the amplitude that generates full power, even if only momentarily. On those peaks the effectiveness of communications rests, and that's why the peak-envelope-power rating is used for ssb transmitters.

## at the receiving end

Recovering the voice modulation from a single-sideband signal has only one difference from ordinary a-m. That difference is in the demodulator. As you learned earlier, the carrier that was removed after modulation is suddenly needed again. The sidebands, whatever their frequency, need a carrier to beat against in the nonlinear demodulator circuit. The process is a form of heterodyning.

Suppose the 14.25-MHz upper sideband is to be demodulated directly. It is necessary to supply a 14.25-MHz rf signal for the 14.2501-14.253 MHz to mix with. Such mixing pro-

duces a signal equal to their sum, slightly above 28.5 MHz, and another equal to their difference, which is .0001-.003 MHz (100 to 3000 Hz). With the usual rf filtering that follows the diode demodulator, it is easy to see that only the block of voice frequencies will be left.

The **accuracy** of the reinserted carrier is of considerable importance. Even a few cycles of error can spoil the recovered voice signals by making their frequencies different from those transmitted. At high radio frequencies, like 14 MHz or thereabouts, controlling frequency so closely can be a problem. Fortunately, with superheterodyne receivers,

that isn't necessary. The incoming single-sideband signal is heterodyned to the receiver's i-f (or i-f's if the receiver uses double conversion). To re-insert the carrier, all that is needed is an accurate CW signal at the frequency of the receiver's last i-f. With that signal and the i-f sideband fed into a non-linear demodulator, voice-signal recovery occurs without complication. **Fig. 7** shows in block-diagram form just how such a system works in one typical double-superhet receiver.

Accuracy of the re-inserted carrier is still important at the lower frequency of the last i-f of a receiver, but it is easier than at high frequencies. Ham-band receivers use last i-f's from 50 kHz to 500 kHz. A common one is 455 kHz. In **fig. 7**, the low i-f frequency is 60 kHz.

The incoming 14.25-MHz sideband (14.2501–14.253 MHz) is first superheterodyned to the high i-f: 2.5 MHz. That makes the sideband 2.5001–2.503 MHz (2500.1–2503 kHz). Second conversion turns the signal into the low i-f: 60 kHz. That places the sideband at 60.1–63 kHz.

The oscillator that provides the carrier for reinsertion is tuned precisely to 60 kHz. In some receivers designed specifically for single-sideband reception, a phase control is accessible to keep that oscillator exactly on frequency. Any slight alteration can distort the recovered voice signals, and the operator needs some degree of control.

### ssb with an ordinary receiver

You don't have to have a special receiver to pick up and listen to single-sideband transmissions. Of course, the specially built ssb set will make the job much simpler, but the fact is that any reasonably stable communications receiver can be used. There is only one requirement: the receiver must have a continuous-wave oscillator (CWO)—the beat-frequency oscillator (BFO) that is used for receiving CW code transmissions (A1). This oscillator can supply the carrier that is needed for reinsertion prior to the demodulator.

You'll need a little practice to become proficient at tuning ssb on your old-faithful ham-band set. First, you must be able to recognize the Donald-duck chatter that is characteristic

of ssb transmissions heard on a double-sideband carrier-dependent receiver. When you come across this phenomenon and would like to de-scramble the jargon, take these steps:

1. Make sure the receiver has been on long enough that all its warmup drift has finished.

2. Turn off the avc. Turn the rf gain control to minimum and the audio gain (volume) control wide open. Leave the BFO (CWO) turned off.

3. Advance the rf gain control enough to hear the QRM across the band.

4. Tune in the signal you suspect of being ssb to its strongest spot on the dial. If you have trouble judging strength, "bracket" the signal: tune halfway between its two fade-out points.

5. Turn on the BFO. "Tune" its pitch control for greatest clarity of the voice. This is critical, so turn the knob slowly till the voice sounds normal. You may have to "ride" the BFO pitch control to maintain clarity, unless your receiver is blessed with an unusually stable front end and beat-frequency oscillator.

There are a couple of characteristics that may hamper your tuning-in and listening to ssb signals. One is the fact that many ssb transmitters use **VOX** transmission—that is, the transmitter is turned on automatically only while the operator is speaking. This may make some ssb signals so intermittent it is hard to get them zeroed-in on the tuning dial. With a little patience, however, you can do it.

Another little problem is the variation in signal strength between transmitters of different powers and distances. With the avc not operating, you may have to juggle the rf gain control a bit between the two sides of an ssb conversation. Don't bother the audio gain control, though. Keep the ssb signal as low as possible in your receiver to avoid overloading; use the rf control for volume adjustment. Again, with practice you will become adept.

That's the ssb story. Make your own decision about whether to go the a-m route or follow the trend to ssb. You can make your decision intelligently now that you know what single-sideband is all about.

**ham radio**

## GOTHAM'S AMAZING ANTENNA BREAKTHRU!!

How did Gotham drastically cut antenna prices? Mass purchases, mass production, product specialization, and 15 years of antenna manufacturing experience. The result: The kind of antennas you want, at the right price! In QST since '53.

**QUADS** Worked 42 countries in two weeks with my Gotham Quad and only 75 watts . . . W3AZR

**CUBICAL QUAD ANTENNAS** — these two element beams have a full wavelength driven element and a reflector; the gain is equal to that of a three element beam and the directivity appears to us to be exceptional! ALL METAL (except the insulators) — absolutely no bamboo. Complete with boom, aluminum alloy spreaders; sturdy, universal-type beam mount; uses single 52 ohm coaxial feed; no stubs or matching devices needed; full instruction for the simple one-man assembly and installation are included; this is a fool-proof beam that always works with exceptional results. The cubical quad is the antenna used by the DX champs, and it will do a wonderful job for you!

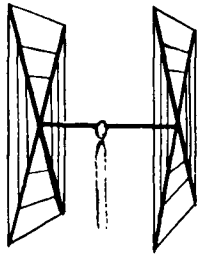

### 10/15/20 CUBICAL QUAD SPECIFICATIONS

Elements: A full wavelength driven element and reflector for each band.

Frequencies: 14-14.4 Mc.; 21-21.45 Mc., 28-29.7 Mc.

Dimensions: About 16' square.

Power Rating: 5 KW.

Operation Mode: All.

SWR: 1.05:1 at resonance.

Boom: 10' x 1 1/4" OD, 18 gauge steel, double plated, gold color.

Beam Mount: Square aluminum alloy plate, with four steel U-bolt assemblies. Will support 100 lbs.; universal polarization.

Radiating elements: Steel wire, tempered and plated, .064" diameter.

X Frameworks: Two 12' x 1" OD aluminum 'hi-strength' alloy tubing, with telescoping 3/8" OD tubing and dowel insulator. Plated hose clamps on telescoping sections.

Radiator Terminals: Cinch-Jones two-terminal fittings.

Feedline: (not furnished) Single 52 ohm coaxial cable.

Now check these startling prices — note that they are *much lower* than even the bamboo-type:

|                             |         |
|-----------------------------|---------|
| 10-15-20 CUBICAL QUAD.....  | \$35.00 |
| 10-15 CUBICAL QUAD.....     | 30.00   |
| 15-20 CUBICAL QUAD.....     | 32.00   |
| TWENTY METER CUBICAL QUAD.  | 25.00   |
| FIFTEEN METER CUBICAL QUAD. | 24.00   |
| TEN METER CUBICAL QUAD..... | 23.00   |

(all use single coax feedline)

How to order: Send check or money order. We ship immediately upon receipt of order by railway express, shipping charges collect.

**BEAMS** The first morning I put up my 3 element Gotham beam (20 ft) I worked YO4CT, ON5LW, SP9ADQ, and 4U1ITU. THAT ANTENNA WORKS!WN4DYN

Compare the performance, value, and price of the following beams and you will see that this offer is unprecedented in radio history! Each beam is brand new! full size (36' of tubing for each 20 meter element, for instance); absolutely complete including a boom and all hardware; uses a single 52 or 72 ohm coaxial feedline; the SWR is 1:1; easily handles 5 KW; 3/8" and 1" aluminum alloy tubing is employed for maximum strength and low wind loading; all beams are adjustable to any frequency in the band.

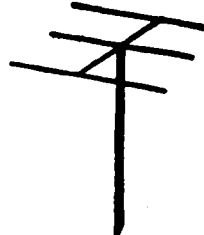

|              |      |              |      |
|--------------|------|--------------|------|
| 2 E1 20..... | \$16 | 4 E1 10..... | \$18 |
| 3 E1 20..... | 22*  | 7 E1 10..... | 32*  |
| 4 E1 20..... | 32*  | 4 E1 6.....  | 15   |
| 2 E1 15..... | 12   | 8 E1 6.....  | 28*  |
| 3 E1 15..... | 16   | 12 E1 2..... | 25*  |
| 4 E1 15..... | 25*  |              |      |
| 5 E1 15..... | 28*  |              |      |

\*20' boom

## ALL-BAND VERTICALS

"All band vertical!" asked one skeptic. "Twenty meters is murder these days. Let's see you make a contact on twenty meter phone with low power!" So K4KXR switched to twenty, using a V80 antenna and 35 watts AM. Here is a small portion of the stations he worked: VE3FAZ, T12FGS, W5KYJ, W1WOZ, W2ODH, WA3DJT, WB2FCB, W2YHH, VE3FOB, WA8CZE, K1SYB, K2RDJ, K1MVV, K8HGY, K3UTL, W8QJC, WA2LVE, YS1MAM, WA8ATS, K2PGS, W2QJP, W4JWJ, K2PSK, WA8CGA, WB2KWY, W2IWI, VE3KT. Moral: It's the antenna that counts!

**FLASH!** Switched to 15 c.w. and worked KZ5IKN, KZ5OWN, HC1LC, PY5ASN, FG7XT, XE2I, KP4AQL, SM5BGK, G2AOB, YV5CLK, OZ4H, and over a thousand other stations!

|                                |         |
|--------------------------------|---------|
| V40 vertical for 40, 20, 15,   |         |
| 10, 6 meters.....              | \$14.95 |
| V80 vertical for 80, 75, 40,   |         |
| 20, 15, 10, 6 meters.....      | \$16.95 |
| V160 vertical for 160, 80, 75, |         |
| 40, 20, 15, 10, 6 meters..     | \$18.95 |

**GOTHAM, 1805 Purdy Ave, Miami Beach, Fla. 33139**

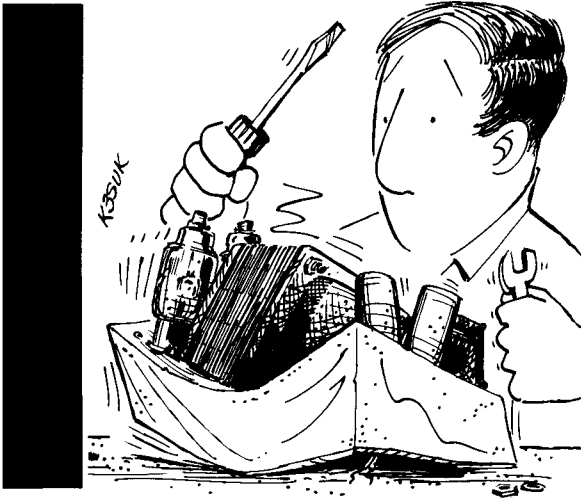

... it may be better  
to use several chassis  
bolted together than  
one large chassis ...

for that

**professional look,**

old man ...

Save money,  
impress your friends!  
Build professional-  
looking homebrew  
ham  
gear

Mike J. Goldstein VE3GFN, 22 Kingswood Road, Toronto 13, Ontario

Are you a **builder** or an appliance operator? If you're a builder, read on; these words are directed to you. If you're an appliance operator, turn the page quickly, for the secrets to be revealed here could usher you into the art of building such magnificent ham gear that you will end up enjoying the awe reserved by your fellows for the successful constructor.

It has been my experience many times in the past few years to have non-hams arrive in my shack, look at a piece of homebrew, and ask where I bought it. Hams who have built equipment themselves have even bought equipment born on my workbench. Since I have been building electronics gear for almost fifteen years (making a living at it at times), I have picked up many ideas and tips that contribute tremendously toward a finished product that is professional looking and a source of pride to me when it is finished. For those of you who are just starting out and don't know where to begin, and for those hardy souls who struggle toward perfection, I submit the following:

The first rule of thumb, and the most important, is to have patience with the job. Think it out beforehand, do it carefully, and don't be satisfied with second best. This is hard when you want to get the job finished, but every rushed job and short cut will hit you right in the eye when you sit back to survey your handiwork. And, you will end up being dissatisfied. Since I have now imparted one-half of my hard-won knowledge, I can proceed to the remainder.

## metalwork

The most popular form of ham-gear construction is the "chassis and panel" type. With this type of construction, everything is mounted on a metal chassis or sub-chassis, with the meters, control knobs and switches

**Cutting holes in metal can be an awful chore . . .**

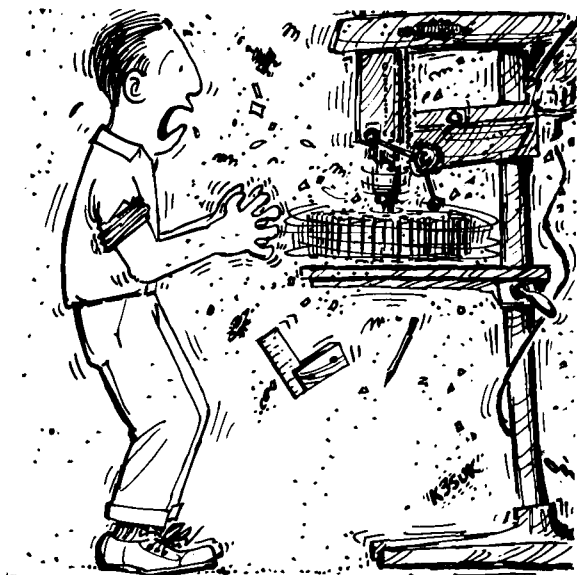

on the front panel. Small units can be built directly into small utility boxes which are commercially available.

While it is certainly cheaper to scrounge sheet aluminum and bend up your own metalwork, the job will turn out poorly unless you have a proper shop at your disposal. It is far better to buy the proper panel and chassis new and start from there. Since aluminum is very easy to work with, use it as much as possible. Always keep a catalogue

of metal parts handy when you're designing a project. Never use painted chassis for building—the grounding problems presented by the paint are horrible, and scraping paint from the inside of a chassis is awkward.

If the job is a large one, it may be better to use several chassis bolted together than one large chassis. This provides shielding between circuits and eliminates flexing which results from a large, flat, metal surface. This can often be a major factor in stabilizing receivers and excitors.

Cutting holes in metal can be an awful chore, or, part of the fun. Let's start with the drill—most of us don't have access to a drill press, but a 1/4-inch drill and a set of **sharp** bits will usually suffice. Set the work on a firm base before drilling and make sure it won't slip. Before drilling any holes, center-punch them first. This centers your hole in the right place and your drill won't slip and gouge the paint or your finger. When drilling, don't exert too much pressure on metal surfaces that will bend easily.

For larger holes, use a little machine oil on the bit. When working on a painted chassis, cover the entire surface with masking tape or thin paper; lay out the hole centers with a pencil and drill through the protective paper layer. Don't remove the paper until all the holes are drilled. Also, don't put an unprotected painted item on your workbench for drilling—all the metal bits you didn't brush off the bench will pepper your paint with scratches. It takes conscious effort not to make this mistake, and I always have a can of spray paint handy for touch-up jobs.

Try to avoid cutting holes with a drill larger than 1/4-inch in diameter. If you need a hole larger than this, cut a small hole and enlarge it to the desired size with larger drills. Larger holes should be cut with chassis punches. If you have a set of punches on the bench, life can be beautiful. A complete set is rather expensive, but you can usually find someone who has the size you need. Since they are so handy, a lot of hams get together and buy a set collectively.

If you have access to a machine shop, a circle cutter can be used instead of a punch. However, don't attempt to use a circle cutter with a hand drill—blood makes a poor lubri-

cant. The **Adel** nibbling tool\* is handy for many metalworking jobs. This gadget will cut practically any size hole in material up to 1/16-inch aluminum or 18-gauge steel, and is practically a machine shop in itself.

When you use a chassis punch, put a little light machine oil on the bolt threads before each hole is cut. Support the punch in a vise if possible. Cut the clearance hole for the punch bolt just large enough for the threads to clear without scraping; then your carefully-placed centers will not be too far off after the hole is cut. One of the greatest **faux pas** you can make is to return a chassis punch with a metal ring inside it; the owner will think twice before lending it again.

Chassis punches can even be used to cut 1/8-inch thick aluminum rack panels; this can be done safely, even with the smaller sizes, if you protect the punch. Turn the bolt slowly and use lots of oil—the shearing torque developed on a punch bolt is surprising.

Since painting or retouching metal is an art, I shall desist from comment except to mention that the aerosol-can spray paints do a beautiful job if you follow the directions on the can.

## mounting components

Once we have the chassis and panel reasonably prepared for construction, we have to consider the problems of mounting components. It has been my sad experience that pre-drilled holes never seem to end up where they should, despite the care I have taken to lay them out. Therefore, I always line up my sockets, control holes, etc., with a grease pencil line so I know how things are going to fit. And, I never drill any holes until I am ready to use them. Otherwise (I confess) I end up with at least one hole in the wrong place. This requires disguising, which is difficult; the “ventilating hole” excuse is thin, at best. If you don’t pre-drill your chassis, you can change your mind as you build without inviting disaster.

As far as the layout is concerned, everybody says “keep it square”—I second the motion. Draw centering lines on the chassis with a grease pencil (washes off with solvent)

\* \$4.15 at Allied Radio, 100 N. Western Ave., Chicago, Illinois 60680. Catalog number 26 B 1153.

so everything fits properly. Even VHF equipment can be laid out neatly, short leads and all. Think the layout out on paper first so you won’t forget some essential component. At one club station I know of, the entire rig and control system sit in a six-foot rack—except for the main high-voltage transformer; this sits in a desk drawer beside the operator. Never did figure that one out.

When components are all mounted, nothing should wiggle. Keep the leads short, and mount all components along tag

**Build everything as though it were going to be used mobile in a Volkswagen during the Shell 4000 Rally.**



(terminal) strips. You can buy these in all sizes and combinations of terminals, so you should have a supply on hand before construction starts. Build everything as though it were going to be used mobile in a Volkswagen during the Shell 4000 Rally. Use lock washers under all nuts.

Uniform hardware adds a great deal to the finished appearance of homebrew equipment. Keep a supply of standard nuts, screws, lock washers, and solder lugs on hand. I stock 6/32 screws in 1/4- and 1/2-inch lengths, with nuts and washers to match, and scrounge the odd sizes as I need them.

Speaking of hardware, never throw any away. When you strip a chassis, throw all the hardware into a box. The gismo you throw

away is exactly the item you'll need next year when Hurricane Whatnot is raging and the world is doomed for the lack of a 3-mil, 1/2-inch white metal bolt with a hex head (thought you'd never need it, hah?). I have saved for years, and haven't been stuck for an odd size yet.

## soldering

Ah, yes, soldering. There are solderers, and there are solderers. I have a friend who takes an hour to install one connector on a cable; the man who can tear it off afterwards is a **strong** man. I also know people who finish large kits in a day, but they are not on the air too much. Rig problems, you know.

Except for big jobs that require a lot of heat, the soldering gun is a crude instrument. The ideal soldering iron is between twenty and fifty watts and has a spade bit not more than 1/4-inch in diameter. If it's easy to re-

**Speaking of hardware,  
never throw any away.**



place bits on your iron, have a machinist friend turn a couple of bits down for fine work. Note that several of the tips manufactured today have a special coating on them to extend their life and prevent pitting—filing or removing the coating will shorten tip life.

When you first use a new tip, dip it into acid-free paste and tin it with the solder you

intend to use. Don't use a rag to clean the tip; keep a tin containing a wet sponge handy and wipe the iron off on that. If you leave a little solder on the tip when the iron is sitting hot, the tip will not pit nearly so rapidly.

The rules for good soldering—clean surfaces, lots of heat, etc., all apply. Since heat rises, put the iron **under** the terminal being soldered. Use a minimum of solder. Don't depend on solder to hold a wire in position. Each wire should be hooked around the terminal to prevent it from springing off. It is a good idea to wrap the wires securely around a terminal if the wiring is to be permanent. It is my observation that the only permanent things in this world are death and taxes, and the former is being disputed in medical circles. Once you have attempted to remove a wire that has been securely wrapped, you will tend to depend on the solder bond for mechanical strength.

If you have to remove the solder to take off a wire or a component, don't just heat the connection directly. The flux in the solder has long since disappeared, and the hot solder will sit there while components and/or printed board char. Take a length of braid (like the shield on small coax) and dip the end in solder paste. Place the pasted end under the solder connection, put the iron against the braid, and press against the solder. The solder will run up the braid, nothing will overheat, and the wires will be exposed. If all the solder doesn't come off the first time, snip off the solder-saturated braid, redip the end, and repeat the process.

When soldering to rotary-switch terminals, it is sometimes difficult to keep solder from running down the terminals into the switch deck. If you "color" the switch terminal just below the solder point with a soft lead pencil, it isn't possible for the solder to flow down too far.

When you're soldering hookup wire, don't grip the wire just above the stripped section—the insulation will stick to the pliers and peel off when they are removed.

## wire

There are many types of hookup wire available, and what you use must be governed only by your finances—buy the best you can

# ADD PUNCH AND CLARITY TO YOUR SIGNAL!



- Instantaneous Limiting Action
- No Appreciable Distortion
- Completely Compatible with SSB
- Talk Power Gain at Least 10 db
- Optimum Frequency Response
- Installs In Microphone Lead
- All Solid State Printed Circuitry

## NEW! COMDEL SPEECH PROCESSOR MODEL CSP-11

A prototype of the CSP-11 has proved itself an effective communication aid on the amateur bands over several years. Its prominent feature is the instantaneous limiting action without the harmonic distortion which often makes the use of conventional speech clippers marginal, particularly with SSB transmitters. Designed for relatively insensitive high impedance microphones—a gain control is provided—the unit will enhance the intelligibility of voice signals considerably under difficult conditions. "MIL" design and construction is employed throughout for high reliability and long life. Power is obtained from internal batteries (6 "D" cells—life exceeds 300 hours) or external source.

*Free brochure will be sent on request*

PRICE: \$120.00 (Subject to Change) Postpaid in U.S.A. (Mass. resident add 3% tax)

**COMDEL INC.**

**Beverly Airport**

**Beverly, Massachusetts 01982**

afford. The best general hookup wire is stranded, number 20 to 24 tinned copper with Teflon insulation. Teflon insulation will never peel back under heat and is really the best stuff to come along in years. The only drawback is that it is expensive. The other types of insulation should be assumed to be susceptible to heat, and proper precautions should be taken to protect it while soldering. My method is to strip the insulation back about  $\frac{1}{8}$ -inch further than I actually require. After stripping, I twist the strands tightly, and tin to within  $\frac{1}{8}$ -inch of the insulation. The tinning allows such a fast transfer of heat that by the time the heat works up to the insulation, soldering is complete. Incidentally, twist and pre-tin all stranded wire, or you will have ends sticking out all over as soon as you try to bend it.

I have not mentioned solid wire because I find it often snaps off after being bent a few times—especially if you're modifying a circuit. Many of you will disagree with me, but I think solid wire just increases your headaches.

## general wiring

Try to cable all the interwiring on a chassis. Use different colored wires so you can easily identify different wires in the cable. Set up a standard color code: green for filaments, red for high-voltage, black for ground, etc., and stick to it. Don't lace your cables—it is difficult enough to modify a cable. If you want to tie them down, tie separate loops at intervals along the cable with waxed lacing cord. You can cut these easily for modifying and then replace. Unlacing a long cable in a tight spot is messy, and while you can sometimes remove a wire, replacing it in a tightly-laced cable is a hairy job indeed!

A better system is to use the small nylon clips which are available in a wide range of sizes. These loop around the cable and are held in place with screws and nuts. They make a beautiful appearance and modifications are a snap.

Two precautions: **never** run any rf or af signal leads (unless they're shielded) in a cable—the resulting pickup and feedback can run you in short circles for a month. Also,



**\$12.95**  
AMAT. NET

**AMERICA'S MOST ADVANCED QUALITY-CONTROLLED BALUN**  
**W2AU BROAD BAND BALUN 2.8 TO 40 MC**  
**WITH BUILT-IN LIGHTNING ARRESTER**  
**HANDLES FULL LEGAL POWER LIMIT**

**\$12.95**  
AMAT. NET

4 PURPOSE BALUN

4 PURPOSE BALUN

THE BALUN THAT HAS BEEN PROVEN AND ACCEPTED. NOW BEING USED BY THE U.S. NAVY, COAST GUARD, AIR FORCE, ARMY, FCC, CIA, RCA, NBC, FAA AND CANADIAN DEFENSE DEPT. AND BY THOUSANDS OF HAMS IN THE USA AND THROUGHOUT THE WORLD.

—ANOTHER FIRST—



Our exclusive sealed type lightning arrester helps prevent lightning damage to your valuable equipment, balun and coax. Don't wait until lightning strikes. Protect your investment now. **DON'T BE MISLED!** Our one style balun is adaptable to all antennas, Yagis, quads, inverted Vees and multi-bands.

Backed by 50 years of electronic knowhow

Proven over the years.

Available at all leading dealers. If not, order direct.  
IT'S WHAT'S INSIDE THAT COUNTS

**W2AU BALUN LETS ENTIRE ANTENNA RADIATE!**

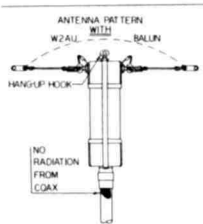

STOP WASTING YOUR SIGNAL! REMEMBER, YOUR ANTENNA IS THE MOST IMPORTANT PIECE OF GEAR YOU OWN.

- No Radiation from Coax
- No Center Insulator Needed
- Perfect for Inverted Vees (Use Hang-up Hook)
- Built-in Lightning arrester
- Broad-Band 2.8 to 40 Mc.
- Takes Legal Power Limit
- Two Models:  
1:1 50 ohm coax to 50 ohm balanced  
4:1 75 ohm coax to 300 ohm balanced
- A must for Inverted Vees, Doublets, Quads, Yagis etc.
- Weighs 6 1/2 oz. 5 1/2" long

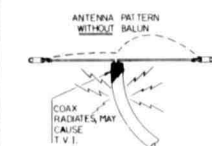

(pat. appld.)

\$ for \$  
Your best balun buy.

**HELPS TVI PROBLEMS IMPROVES F/B RATIO BY REDUCING LINE PICKUP**

**UNADILLA RADIATION PRODUCTS, Mfrs. of Baluns & Quads, Unadilla, New York 13849**

don't solder directly to the chassis—use solder lugs held in place with screws, nuts, and internal-tooth washers.

**the finishing touch**

When the unit being built has been tested and debugged, the last decals are drying on the front panel, and the TVI tests show negative, the time has **not** come to place your masterpiece in the console. Not yet.

While it is all open in front of you and your memories are fresh, collect all your notes. Draw a schematic diagram, and make sure all the changes you made along the way are incorporated. Jot down the calibration

procedure you discovered was the best. Make a note of the current and voltage readings at pertinent points. Your memory isn't nearly as good as you think, and this information will be necessary if anyone else ever inherits the equipment. Finally, file the information away where you can find it in a hurry.

There it is. You've done a nice job, and it looks as good as it works. It took a little longer, and perhaps cost you a little more, but, "Say, Sam, where did you buy that classy-looking rig?"

ham radio

**next month in ham radio magazine:**

- Full-Blast Operation of TV Sweep Tubes
- Long-Tail Transistor Biasing
- Double-L Baluns
- Low-Voltage, High-Current Power Supply
- Transistor Voltmeters
- APX-6 Notes

- Linear Power Amplifiers
- E-Z Antenna Impedance Bridge
- Station Control
- VHF Weather Receiver
- Two-Meter Mobile
- Plus much more!

# whips and loops as apartment antennas

If you're stuck with  
a poor antenna because  
you  
live in an apartment,  
try one of these  
recommended  
by W2EEY

John J. Schultz W2EEY/1, 40 Rossie Street, Mystic, Connecticut 06355

I have lived in a lot of apartments and tried various solutions to the problem of putting up a reasonably useful indoor or balcony-type antenna for 80- through 10-meter coverage. Most apartments have sufficient space to string enough wire around so that a transmitter will load properly, but getting efficient radiation often calls for the experimental approach.

Strictly indoor antennas—types which are erected **wholly** within an apartment—seem to be the least effective. They often load well, and the SWR may be extremely low when they are carefully cut to resonance. However, much of the radiated energy is absorbed by the surrounding structure and lost. When the same antennas are placed in a wooden frame building they perform fairly well. This is particularly true when they are mounted in the attic away from the wooden structure.

Generally speaking, however, a smaller antenna erected on the outside of the building will perform better. I should point out that antennas which are placed outside a building, but very close to it, don't work too well. An example is a wire from an apartment window or balcony along the side of the building. This antenna can be made to load rather well, but it will couple most of the rf energy into the building. Antennas of this type are generally only useful when local coverage is desired.

I will describe two antennas here which can be used for this purpose: the loaded-whip and the loop antenna. The loop is particularly interesting because when it is properly fed, it is surprisingly efficient, even when relatively small.

## loaded-whip antennas

When you must operate from an apartment, the antenna problem is very similar to the mobile installation. When the antenna is indoors, the structure effectively shields it. Unfortunately, there is usually only limited space available to erect the antenna outdoors. The ground point is an indefinite thing, especially at the lower frequencies where a good electrical ground is desirable.

Since apartment antenna problems are similar to mobile operation, many of the techniques which have been applied to

fig. 1. A wire antenna hung along the wall of a modern apartment building (A) couples most of its energy into the building structure as does a window- or balcony-mounted vertical whip (B). The whip should be installed with as great an angle as possible (C and D) from the surface which acts as its ground plane.

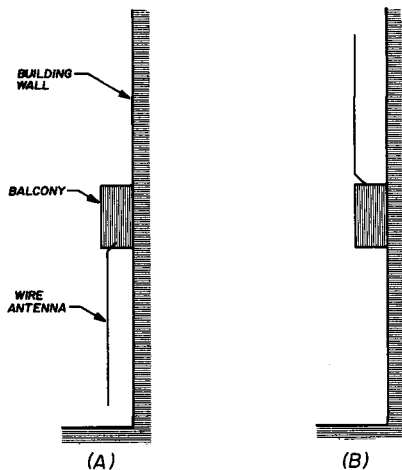

mobile antennas are useful for apartment dwellers.

The loaded-whip antenna is not an efficient radiator, particularly on the lower-frequency amateur bands, but it is still one of the best solutions to the mobile antenna problem. Mounted vertically on the automobile, it provides a vertically-polarized radiation pattern of more or less circular shape, depending where it is mounted on the car. The antenna works against the ground plane provided by the automobile and the earth.

When an antenna is used by an apartment dweller, the idea of this **ground plane** is very important. If the antenna is used in an apartment high above the ground, the side wall of

the building becomes, in effect, the plane against which the antenna operates. And, for best results, the antenna must be mounted at right angles to this ground plane.

As the antenna is tilted closer to the building surface (toward the vertical), the effective radiated signal decreases rapidly. Although I have made no formal measurements, experience with a ten-foot base-loaded whip in a fourth-floor apartment bears this out. As a balcony-mounted antenna was tilted from a position 90° to the building structure to within about 30° from the structure, signal reports decreased at least 4-6 S-units. The effect is similar to a vertical quarter-wave whip when it is lowered toward the ground.

Because of this effect, recognition of the true ground plane is important. Therefore, a

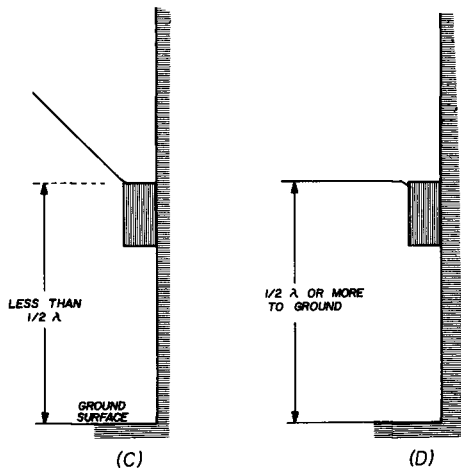
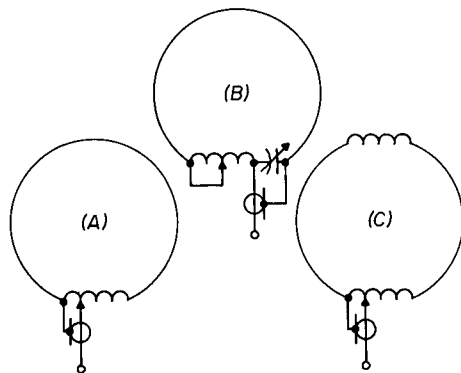

fig. 2. A simple inductive-loaded loop antenna (A) and variations which may be used for operation from 80 through 10 meters. This type of antenna is inefficient because of the loading.



whip used by the apartment dweller should be placed at right angles to its ground plane, not 90° to the earth. This may change for lower-level apartments because of the effect of the closer ground level. In any case, only a series of actual on-the-air checks can determine the best position for a particular installation.

The effectiveness of the ground connection used in an apartment station is just as important as in a mobile. The mobile ground connection is limited by the fact that the tires effectively isolate the body of the automobile from earth ground. Also, the metal parts of the automobile are not bonded together with low-loss electrical connections. On the lower high-frequency amateur bands it is often necessary to bond the major surfaces of the automobile together with ground straps for best performance.

In an apartment, metal balcony frames and window frames can be used for ground connections but these surfaces must present a relatively large low-loss interconnected mass to be effective. Welded balconies are effective, but screened surfaces which are pressure bonded may present high electrical resistance. Water or heating pipes in an apartment building usually present such a high-loss path to ground that they are useless.

With care in orientation to the building, and a decent ground connection, balcony- or window-mounted whips can be as efficient as a mobile whip. In practice, they are sometimes more effective because of their elevation above ground obstructions. It doesn't seem to matter a great deal whether the whip is base-, center- or top-loaded.

A good ground connection is more readily achieved in an apartment installation than in a mobile. On 10 and 15 meters, where the physical length of a whip can approach a quarter wave, there seems to be a definite advantage to moving the loading coil as far out on the whip as possible. Otherwise, the location of the loading coil on a whip which is less than 10 feet long seems to have little effect on field strength; and, when the coil is mounted at the base of the whip, band-switching is simplified.

The use of a base- or center-loaded whip antenna in an apartment will generally prove

superior to an antenna erected inside the apartment or a wire hung along the side of the building. However, the whip must be properly oriented and a low-loss ground connection or ground surface must be provided.

### small-loop antennas

Loop antennas are often used for restricted-space antennas because they may be resonated without the need for a low-loss ground connection. Also, when they are physically small, they are vertically polarized and can be mounted next to any large surface mass. A loading coil is generally used

**fig. 3.** Because of its inductive property, a loop can be resonated by a capacitor (A) or capacitive divider (B). The scheme in A is useful with high-impedance feedlines while B is more suitable for 50- or 75-ohm lines. The values shown in B are for a 20-meter loop antenna, 20 feet in circumference, constructed of one-inch tubing.

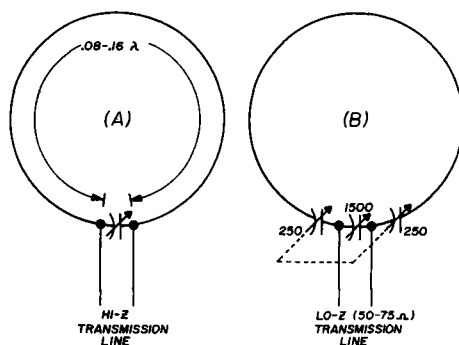

as shown in **fig. 2A** to increase the electrical length of the loop to one-half wave, the length of a self-resonant loop.

The radiation resistance presented by loops is very low; their efficiency is dependent upon the losses of the loading coil. Variations of the basic loaded loop are shown in **fig. 2B** and **2C**. In both cases, if the loop is made from one inch or greater diameter tubing, the major losses occur in the loading coil.

The loops I am talking about here are on the order of 0.08 to about 0.16 wavelengths long. These loops are short enough so that the current is in phase and essentially the same amplitude throughout the loop. The radiation is vertically polarized and the directive pattern is similar to a dipole. Maximum radiation is in line with the plane through the sides of the loop.

Inductive loading is not the only method that may be used to make a small loop resonate. Unlike any other short antenna, the loop has a unique, inductive property which is determined by the area of the loop and the type and size of conductor used in its construction. You can take advantage of its inductive quality and use an external capacitance as shown in **fig. 3A** to resonate it. The overall effect is basically the same as inductive loading. Theoretically, you can't obtain more efficient coupling of power by either method. However, in practice, air-variable or mica capacitors have far less dissipative losses than a loading coil; and, the capacitive method of resonating the loop is far more efficient. The efficiency of a 0.16-wavelength loop approaches that of a full-size half-wave dipole antenna. Smaller loops are less efficient, but far better than inductively-loaded, shortened antennas.

You can visualize the loop as a simple parallel-resonant circuit consisting of the inductance of the loop and the resonating capacitor. When a low-impedance transmission line is connected across such a circuit, a high standing wave ratio results. To match the low-impedance line, either an inductive or capacitive tap system can be used. However, the capacitive system is much more practical and easily achieved by splitting up the resonating capacitor as shown in **fig. 3B**. If you are familiar with the **Transmatch\*** antenna coupler, you will recognize that this is basically the same matching system.

If we assume that the capacitor losses are fixed, the overall losses will depend upon the conductor losses in the loop. Low conductor losses are achieved by constructing the loop of one-inch or larger diameter tubing. Low-resistance connections between the loop and the resonating capacitors are an absolute necessity. A wide, flat, strip of metal may also be used to form the loop since the objective is to achieve as large a surface area and, therefore, inductance. A square loop with the same maximum radii as a circle will enclose about one-third less area; the inductance and efficiency will decrease in about the same order.

\* L. McCoy, "The 50-Ohmer Transmatch," *QST*, Vol. 45, July 1961, p. 30.

**Fig. 3B** shows typical values of capacitance necessary to resonate a twenty-foot loop (circumference) on 20 meters. Proportionately more capacitance will be required on lower frequency bands and less on 15 meters. The capacitors should be air-variable types for the greatest possible Q. Matching adjustments are basically the same as a Transmatch antenna coupler. First, the center capacitor and then the two outer capacitors are varied (simultaneously) to obtain a low SWR on the transmission line. The adjustment is a back-and-forth procedure from the center to the outer capacitors.

Once the approximate capacitance value has been determined, two of the variable capacitors may be replaced with fixed values—fine tuning is accomplished with one capacitor variable. Bandswitching can be accomplished in the same fashion since the capacitor values for each band have been determined experimentally.

Such conventional qualities as angle of radiation and directive patterns are almost impossible to establish for such an antenna. The directive pattern will usually be entirely dominant in the direction away from the building surface. However, the lowest angle of radiation and best DX will generally be achieved in directions which are an extension of the building plane against which the antenna is mounted. This factor is true for the loop-type antenna as well as the whip.

## summary

Apartment antennas present a frustrating but challenging situation as far as antenna erection is concerned. Probably more than any other factor, aesthetic considerations govern the type of antenna which can be used. An outdoor antenna will invariably produce better results than an indoor one.

The most efficient small antenna is the loop; it is also an antenna which can be made small and unobtrusive. If the loop antenna is properly tuned with a capacitive matching circuit and constructed of heavy low-loss "hardware," it will delight the apartment dweller who has given up hope of satisfactory operation on the high-frequency ham bands.

ham radio

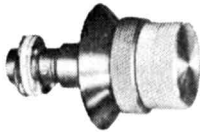

**2 SPEED  
DRIVE UNIT**

For professional, sophisticated gear. Slow motion 4.5:1 drive shaft controlled from 1" dia. satin anodized aluminum knob. Direct drive operated by 1 1/2" dia. dial. Mounts on outside of any thickness panel.

Model 4832/2K ..... \$4.95



**NEW 6/36  
DRIVE**

Improved model with improved clutch mechanism for even longer life. New black escutcheon is plastic coated to insure great durability. Co-axial spindle provides 6:1 and 36:1 under control of one knob.

Model 4103/A ..... \$7.50



- AM, CW or SSB
- Wave envelope or trapezoid patterns
- No tuning required
- Up to 60 Mc
- Will handle 5W to 1 KW
- Uses standard connectors
- Internal sweep
- Size: 9 1/2" deep, x 5 1/2" high, x 3 1/2" wide
- Weight: approx. 5 lbs.

**\$29.95**

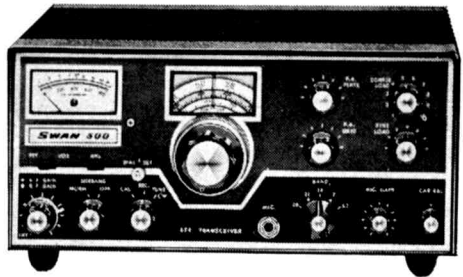

**SWAN 500**

**5 BAND—480 WATT SSB TRANSCEIVER  
FOR MOBILE—PORTABLE—HOME STATION**

The first twenty replies only

**\$395.00**

**ACCESSORIES:**

- Full Coverage External VFO. Model 410 ..... \$ 95
- Miniature Phone Band VFO. Model 406B ..... \$ 75
- Crystal Controlled Mars Oscillator, Model 405X ... \$ 45
- Dual VFO Adaptor. Model 22 ..... \$ 25

**A COMPLETE LINE OF**



**VERTICAL ANTENNAS**

MODEL 18AVQ . . . A high-performance all-band vertical for under \$50.00 . . . You asked for it . . . HyGain built it. Automatic band switching all-bands 10 thru 80 meters. Features individually tuned Hy-Q traps that provide peaked performance on each band. Takes maximum legal power. Feeds with 52 ohm coax. SWR less than 2:1 on all bands. Simple to install on ground or rooftop. Withstands 100 MPH winds when properly guyed. Model 18AVQ \$49.95 NET



**OTHER MODEL VERTICALS  
IN STOCK.**

- 14AVQ 10 thru 40 Meters \$32.50
- 12AVQ 10, 15 & 20 Meters \$24.50

**COME VISIT ARROW'S NEW  
NEW YORK CITY STORE AT  
97 CHAMBERS STREET**

**ARROW ELECTRONICS INC**

• 900 Rte. 110, Farmingdale, N. Y.  
516 — MYrtle 4-6822

- 97 Chambers St., N. Y., N. Y. • 525 Jericho Tpke., Mineola, N. Y. • 18 Isaac St., Norwalk, Conn. • 225 Rte. 46, Totowa, N. J.
- 212 — DIgby 9-4411      516 — PIONEER 2-2290      203 — 838-4877      201 — 256-8555

# SEND PERFECT CODE—EASILY!



**\$85.00**  
**WIRED AND TESTED**

**WITH THE NEW**

DA

## DIGITAL AUTOMATIC I. C. KEYS

The "Iambimatic" concept together with dot and dash memories makes using the DA a pleasure. In just a few days, following the lessons in the DA instruction manual, you will send perfect code with amazing ease and become proficient in just a few weeks. A new concept in keyer design, the DA provides many unique features making automatic keying practical for even the occasional c.w. operator.

### CHECK THESE FEATURES

- Dot and dash memories
- Precision double paddle—built in (provision for external paddle)
- Teflon® bearings (lowest coefficient of friction of any solid)
- "Squeeze" character formation—no difficult letters
- Dots and dashes self-completing
- "Iambimatic" action—alternates dots and dashes with both paddles closed
- Dual insertion—dots may be inserted on a closed dash paddle and dashes may be inserted on a closed dot paddle
- Built-in monitor with tone and volume controls and a 4½" PM speaker
- 6-60 WPM
- 50 VA precision reed relay
- Digital circuitry
- 6 dual I.C.'s plus 2 transistors and one diode for optimum circuit performance
- Free running multi-vibrator—every character perfectly formed
- Completely portable
- Low power consumption (less than ½ watt in battery mode) for battery life over 150 hours
- Versatile power requirements—internal batteries or 10-14 VDC at 100 Ma. (intermittent) or 6.3 VAC at ¼ A (with DA-3 option)
- Zener regulator for voltage

- stability
- Compact 3" x 4¾" x 8¼"
- Solid construction
- Top quality components
- Completely wired—ready for use
- Full one year warranty
- Complete instructions including practice texts.

### SPECIFICATIONS

#### CIRCUIT:

**Speed Range:** 6-60 WPM. **Keying Output:** key line to chassis ground. **Maximum Open Circuit Voltage:** 250 V. **Maximum Keyed Current:** 3 A. **Maximum Keyed Power (open circuit voltage times keyed current):** 50 Watts. **Audio:** internal PM speaker. **Power Requirement:** Internal batteries (30 Watt), or 10-14 VDC at 100 Ma. (intermittent), or 6.3 VAC at ¼ A—neither side ground (with DA-3 option). **Battery Life:** over 150 hours (mercury), over 50 hours (carbon).

#### CONTROLS:

**Front Panel:** Speed control, Internal/Off/External Power Switch, Dot Paddle, Dash Paddle. **Inside Case:** Tension, Dot Gap, Dash Gap. **Rear Panel:** Monitor Volume Control, Monitor Tone Control, Key (for external straight key), Paddle (for external paddle), External Power Terminals (Ground, +10-14 VDC, Extra for 14-30 VDC with series resistor, ±6.3 VAC).

#### MECHANICAL:

**Size:** 3 x 4¾ x 8¼ (case). **Weight:** 4 lbs. **Shipping Weight:** 4½ lbs. (DA-3 ¼ lb.)

DA keyer (Less batteries).....\$85.00  
DA-3 Optional 6.3 VAC Power Supply.....\$12.50

**ORDER FROM OR VISIT THE AUTHORIZED DISTRIBUTOR NEAREST YOU—ASK ABOUT BUDGET TERMS**

#### HARRISON RADIO CORPORATION

|                      |          |       |
|----------------------|----------|-------|
| NEW YORK             | NEW YORK | 10007 |
| JAMAICA, L.I.        | NEW YORK | 11435 |
| E. FARMINGDALE, L.I. | NEW YORK | 11735 |

#### HENRY RADIO Inc.

|             |          |       |
|-------------|----------|-------|
| LOS ANGELES | CALIF.   | 90064 |
| ANAHEIM     | CALIF.   | 92801 |
| BUTLER      | MISSOURI | 64730 |

#### WESTERN RADIO

|           |        |       |
|-----------|--------|-------|
| SAN DIEGO | CALIF. | 92101 |
|-----------|--------|-------|

#### WORLD RADIO LABS Inc.

|                |      |       |
|----------------|------|-------|
| COUNCIL BLUFFS | IOWA | 51501 |
|----------------|------|-------|

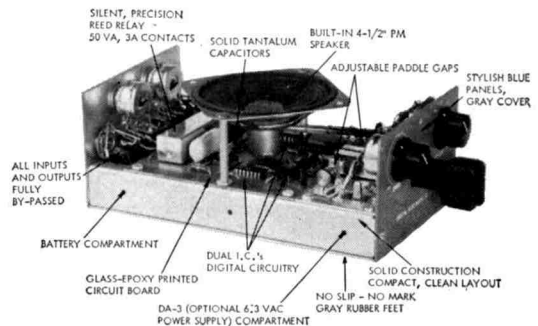

MEGA ELECTRONICS COMPANY

10463 ROSELLE STREET, SAN DIEGO, CALIFORNIA 92121, PHONE (714) 453-0231

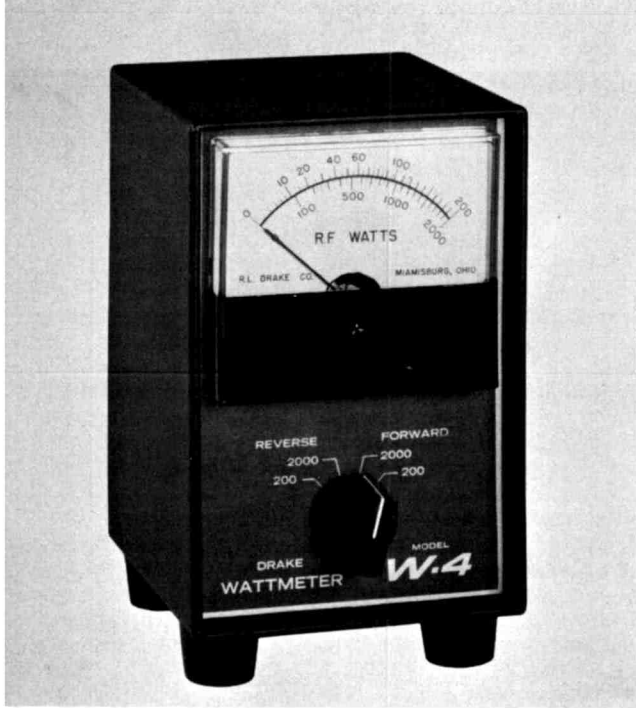

the  
**Drake W-4**  
directional rf  
wattmeter

Zero to  
2000 watts with  
good accuracy  
to  
50 MHz

Jim Fisk W1DITY, RFD 1, Box 138, Rindge, New Hampshire 03461.

Today, very few amateurs would even consider going on the air without some type of SWR indicator or directional wattmeter in the transmission line. There are many reasons for this. First of all, the popularity of the moni-match-type SWR bridge. Secondly, most ssb transceivers are designed for a relatively narrow range of load impedances. If your antenna isn't resonant, or the matching system isn't adjusted correctly, the transceiver will not load properly.

There are several disadvantages to the low-cost SWR meters that most hams have in their shacks. Most important, their directivity is only about 20 dB, so the best VSWR you can possibly measure with them is 1.7:1. If you use one, and are claiming an SWR of 1:1, you're not kidding anyone but yourself. Another disadvantage of the monimatch-type coupler is its frequency sensitivity. As you raise the frequency of your transmitter, the unit becomes more and more sensitive. Therefore, to use it to measure actual power, it has to be calibrated throughout the frequency range at which you want to use it.

SWR indicators and directional watt-meters



both make use of the fact that the forward components of voltage and current along a transmission line are in phase, while the reflected components are out of phase by 180° and cancel. A small voltage derived from the current in the line is added to the voltage across the line. With proper construction and choice of components, this sum represents only the forward power. If the phase of the current sample is shifted by 180°, the forward components cancel and the sum represents only the reflected power.

In the monimatch-type SWR indicator, a small loop is placed next to the transmission line. The current in the line induces a voltage into the loop; the voltage sample is provided by capacitive coupling of the loop to the line. The sensitivity increases with frequency be-

fig. 1. Circuit diagram of the Drake W-4 directional rf wattmeter.

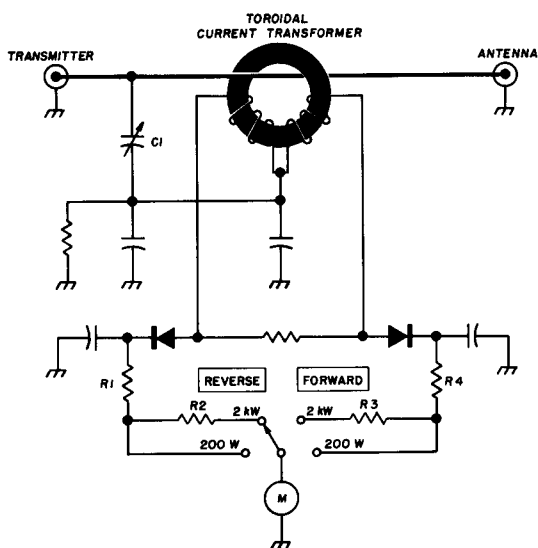

cause the current induces more voltage into the loop because its inductance is increasing, and the voltage sample increases because the capacitive reactance is decreasing. Fortunately, the current and voltage ratios remain constant, so the unit will indicate the proper SWR over rather wide frequency ranges. However, since it is frequency sensitive, it is impossible to make power measurements without an involved calibration process.

The Drake\* W-4 wattmeter uses a method of obtaining the necessary voltages which is

not frequency sensitive in the range of interest, 2 to 30 MHz. In the W-4, the current in the transmission line induces a voltage in a toroidal current transformer (fig. 1). A Faraday shield eliminates any capacitive voltage pickup by the toroid which would affect accuracy. The capacitive voltage pickup is provided by a small variable trimmer (C1) connected across the line. The sum of the two rf voltages is rectified by a diode (one for forward power and one for reverse) and measured by a meter which is calibrated in watts. The variable resistors R1-R4 are used for calibration.

Now, the reason for the W-4's frequency independence. The voltage sample is independent of frequency because it is taken through a capacitive voltage divider. Although capacitive reactance decreases with increasing frequency, the ratio between the two parts of the divider remains constant, so the voltage sample at the tap does not vary with frequency, other things being equal. The current is independent of frequency because the reactance of the toroidal coil goes up at the same rate as the induced voltage.

With this type of coupler, frequency response is limited primarily by the coil. At the

\* R. L. Drake Company, 540 Richard Street, Miamisburg, Ohio 45342.

#### W-4 specifications

|                     |  |
|---------------------|--|
| frequency response: | 2 to 30 MHz, usable at 50 MHz with correction factor                               |
| impedance:          | 50 ohms  |
| VSWR insertion:     | 1.05:1 maximum   |
| power capability:   | 2000 watts continuous  |
| accuracy:           | ± 5% + 2 watts on 200-watt scale, ± 5% + 20 watts on 2000-watt scale from 2-30 MHz |
| connectors:         | SO-239   |
| size and weight:    | 6" H × 3-11/16" W × 4" D; 2 pounds   |
| price:              | \$49.50  |



# PRESENTING THE ALL NEW **AMECO PT** ALL BAND TRANSCEIVER PREAMPLIFIER



- **6 THRU 160 METERS**
- **FEEDS 2nd RECEIVER**

Model PT, with built-in power supply, transfer relay, connecting cables, wired and tested.

Amateur Net ..... **\$49.95**

- A frame grid pentode provides low noise figure with ability to handle strong signals, greatly improving the sensitivity of the receiver section of a transceiver.
- A unique built-in transfer circuit enables the PT to by-pass itself while the transceiver is transmitting. The PT also feeds the antenna input of a 2nd receiver as well as muting it.

## **AMECO EQUIPMENT CORP.**

**A SUBSIDIARY OF AEROTRON, INC. ■ P. O. BOX 6527 ■ RALEIGH, N. C. 27608**

lower frequencies, response is limited by the point where the reactance of the coil causes a noticeable phase error. The upper-frequency end is limited primarily by the series self-resonance of the coil, although lead length of resistors and capacitors is also important.

The design of the W-4 is such that its frequency response is down by 2% at 2 and 30 MHz. Within this range the accuracy of the instrument is  $\pm 5\%$  of the reading  $\pm 2$  watts on the 200-watt scale, and  $\pm 5\%$  of the reading  $\pm 20$  watts on the 2000-watt scale. Above 30 MHz slight errors began to creep in because of phase-shifts, but correct readings may be obtained on the 50-MHz band by multiplying the indicated power by 1.111.

Since it absorbs negligible rf power, it may be left in the line at all times. One nice feature of the W-4 is the removable coupler. It may be removed from the main cabinet and put in a remote location, up to three feet away from the box containing the meter and function switch.

To put the W-4 wattmeter into operation, all you have to do is insert it in the transmission line and set the function switch to

the appropriate range. In the "forward" position, it measures the power that the transmitter is putting into the line. In the "reverse" position, it measures the power that is reflected from the antenna. To determine how much power is actually being radiated (assuming a lossless transmission line), all you have to do is subtract the reverse power from the forward power.

Since the W-4 is primarily a wattmeter, it doesn't measure SWR directly. However, with the forward and reverse power measurements, it is relatively easy to determine. You don't have to make any calculations either—Drake has thoughtfully included a nomograph with the unit that does all the work for you. It's printed on plastic, so it won't get dog-eared with age, and there's a convenient storage place for it in back of the meter box.

Most amateurs are interested in how well their antenna is matched, and even more interested in how much power they are getting into the transmission line. The Drake W-4 wattmeter provides both of these functions with good accuracy up to 50 MHz.

**ham radio**

# The Tube That Puts The Big Value In The Heathkit® SB-200

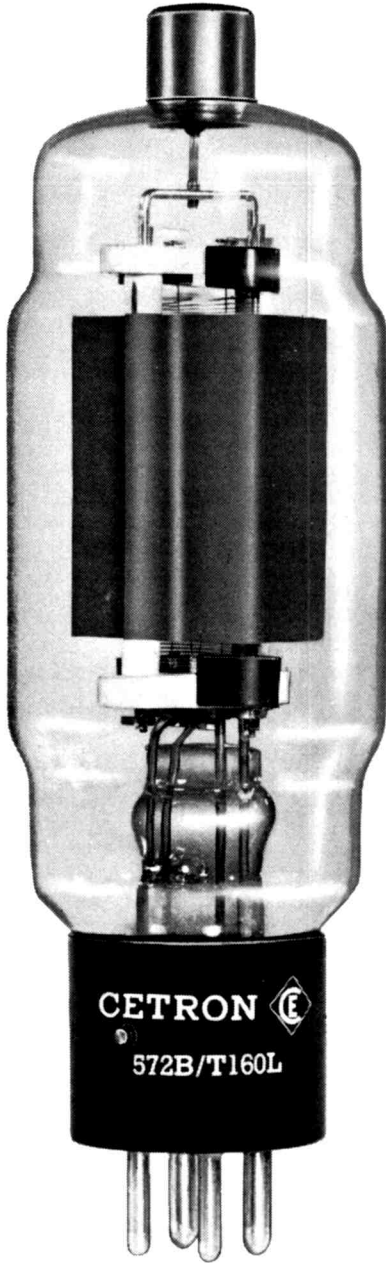

(Shown Actual Size)



## CETRON 572B/T-160L

*Especially designed to fulfill the optimum cost and performance requirements of amateur radio KW SSB linear amplifiers, a pair of CETRON 572B/T-160L's in parallel provides all the muscle you need at a price you can afford. T-160L is one of more than 30 tube types manufactured by CETRON. Formerly Cetron-Taylor, Cetron Electronic Corporation has been a supplier of amateur radio tubes since 1931.*

### 572B/T-160L SSB Grounded Grid Linear Amplifier Service Maximum Ratings Per Tube

|                                 |              |
|---------------------------------|--------------|
| DC Plate Voltage.....           | 2750 volts   |
| DC Plate Current.....           | 275 ma       |
| Plate Dissipation.....          | 160 watts    |
| Filament Voltage & Current..... | 6.3 v @ 4.0A |

### Typical Operation — Two Tubes (ICAS)

|                                   |            |
|-----------------------------------|------------|
| DC Plate Voltage.....             | 2400 volts |
| DC Grid Voltage.....              | -2.0 volts |
| Single Tone DC Plate Current..... | 500 ma     |
| Zero Signal DC Plate Current..... | .90 ma     |
| Driving Power.....                | 100 watts  |

• Features a rugged graphite anode • Durable bonded thoriated tungsten filament • Optimum envelope size for minimum cooling requirements vs. space considerations • Low operating voltage for minimum power supply cost

Put It To Work In Your Home-Brew Linear . . .  
Available Through Your Dealer Or Write



## CETRON ELECTRONIC CORPORATION

715 HAMILTON STREET  
GENEVA, ILLINOIS

NEW

# Poly Quad

ANOTHER GLASDRAMATICS EPOXY-FIBERGLASS PRODUCT

**STRONGER...MORE EFFICIENT...  
MORE ECONOMICAL!**

2 el... tri-band (20-15-10)

**POLY tri QUAD  
KIT**

**\$59<sup>95</sup>**

F.O.B.  
Walkerton  
or include  
\$3.50

- 8 Zip-Glas Spreaders (13')
- 2 Universal Starmounts
- 1 Boom-to-Mast Adapter
- 1 Instruction Manual

...this great new kit offers you power gain comparable to a 3 el beam, yet so lightweight you can rotate it with a TV rotor...all the superior efficiency of the quad...lower angle of radiation...greater capture area...reduced ORN and QSB...plus rugged Poly Quad quality construction...and all at an amazingly low price...

3 el Kit..... \$ 89.95

4 el Kit..... \$119.95

**Not Ready For Tri-Band?**

...you get the same quality with POLY duo QUAD Kits (15-10) starting low as \$54.95 and 10 meter POLY mono QUAD Kits...for further information about kits or individual components write directly to Polygon Plastic Co.

**EXCLUSIVE  
Zip GLAS  
TELESCOPIC  
FIBERGLASS  
SPREADERS**



action engineered with compressional and tensional strength superior to anything else on the market... prestressed...lightweight...epoxy impregnated, epoxy painted so they're corrosion resistant... won't shrink, split or splinter... jam open in seconds...tested for winds in excess of 80 mph... sky-blue color to reduce neighbor and XYL objections...



**What Makes Poly Quad So Different?**

Glasdramatics — Polygon's exclusive, patented process of weaving, winding and drawing continuous strands of fiberglass filaments before permanently bonding with resins.

**EXCLUSIVE UNIVERSAL  
Starmount**

you save... the Poly Quad Starmount accepts 2" to 3" boom o.d....move up to multi-el array without discarding this hardware... rigidly die-cast of 360 aluminum alloy... tested in many marine applications... proved to withstand nature's toughest test—salt water...

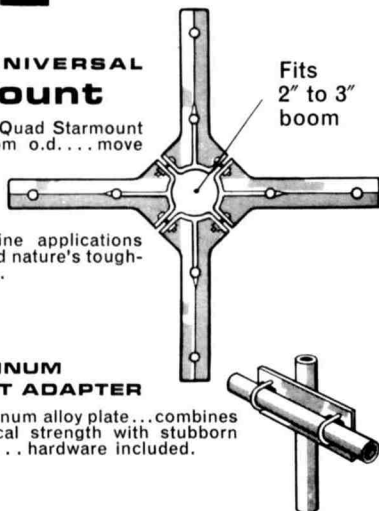

Fits  
2" to 3"  
boom

**RUGGED ALUMINUM  
BOOM-TO-MAST ADAPTER**

brawny 5052-H34 aluminum alloy plate...combines the best of mechanical strength with stubborn corrosion resistance... hardware included.



**POLYGON PLASTIC COMPANY, Division of Plas-Steel Products, Inc.**  
7 Industrial Park • Walkerton, Indiana 46574 • Phone 586-3122.

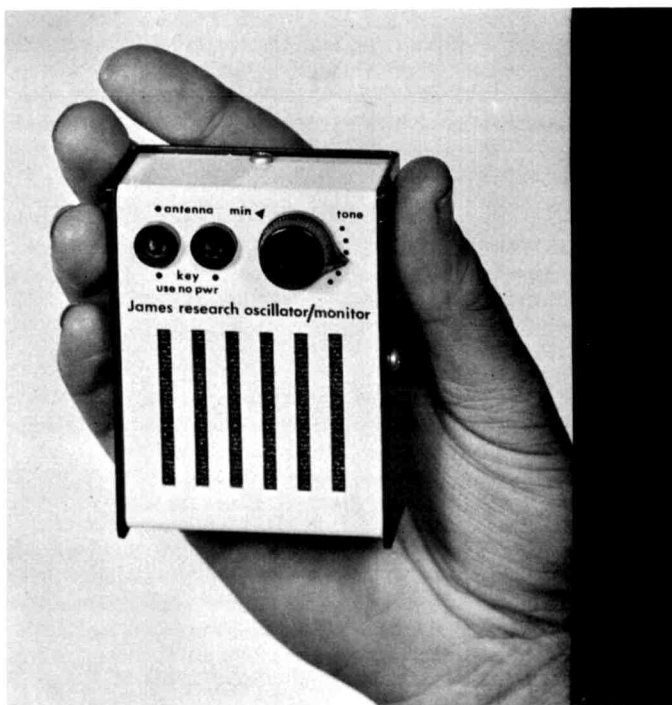

the  
**James Research**  
**oscillator/monitor**

**Jim Fisk W1D TY, RFD 1, Box 138,  
Rindge, New Hampshire 03461.**

**At first glance** the James Research\* oscillator/monitor appears to be just another code-monitoring gadget. Not so. It's a whole lot more. It may be used for checking continuity, testing resistors or even checking components. It is a very sensitive rf detector, providing an audible output with inputs down to 10 milliwatts with an eight-inch pickup antenna. By connecting it directly to the rf source, sensitivity is increased considerably. In addition, of course, it will provide a CW sidetone of your transmitted signal without direct connection to your transmitter or serve

\* James Research Company, 11 Schermerhorn Street, Brooklyn, New York 11201.

as a code-practice oscillator.

If you're doing any trouble shooting, it gives rapid indications of continuity and open components. It's a lot faster than the old ohmmeter approach, because you don't have to look up at a meter as you go from point to point. You can even check electrolytic and coupling capacitors down to about 0.5  $\mu$ F. If the capacitor is good, you'll get a short tone burst as it charges; if it's open, no tone; shorted, steady tone. You can even guess capacitor values by the length of the tone burst, but it takes a little bit of practice.

The oscillator/monitor is also great for checking semiconductors, either transistors or diodes. In addition to indicating open and shorted junctions, it will show polarity, anode or cathode, NPN or PNP. If you've ever graded semiconductors with an ohmmeter, you know how long it takes. With the oscillator/monitor it takes a matter of seconds. In fact, I just went through an assortment of 100 diodes and checked them all in less than two minutes. Transistors take slightly longer because you have to check two junctions instead of one, but it is still very fast.

Because of the high-gain dc amplifier which is incorporated into the unit, it is a very sensitive rf detector. With an eight-inch length of number 14 bus wire as a pickup unit, it will provide an audible output when placed near rf sources down to 10 milliwatts or so. If you want to check lower-powered rf sources than this, it may be connected directly. However, don't connect it directly to an rf source greater than 100 milliwatts—you're liable to burn out the input circuit. However, in amateur applications, power levels will usually be above the 10-milliwatt level, even with transistor circuits.

To use the oscillator/monitor as a CW monitor of your transmitted signal, simply place it in close proximity to your transmitter. As the transmitter is keyed, it will emit an audio tone. It may also be used to tune your transmitter for maximum output. In this case, put the oscillator/monitor just close enough to the transmitter so the oscillator just barely triggers. Then, as you tune the transmitter up, and the power increases, the tone will change.

For use as a code-practice oscillator, just

connect your bug or key across the input terminals. The audio output can be heard throughout a rather large room. You can also set up two units for code practice between two different locations. Because of the low current involved at the input terminals, resistance of long connecting wires has little effect on their operation, and the oscillator/monitors can be separated by quite long distances.

The circuit of the James Research oscillator/monitor is really quite straight-forward—a broadband rf detector coupled to a high-gain dc amplifier which triggers an audio tone oscillator. Since the input circuit is untuned, it will respond to rf sources from 100 kHz to 1000 MHz. Also, resistance from zero to 100,000 ohms will trigger the oscillator directly from the internal 1.5-V battery. Trigger current varies from 50 to 100  $\mu$ A, depending upon the resistance across the input terminals.

The unit is well packaged—16 gauge aluminum. A lasting finish is provided by black and white epoxy resin. For convenience, a magnet is attached to the back. In addition to holding the oscillator/monitor to any steel surface, it grounds the unit for better rf pick-up. All things considered, a versatile, well-designed and useful little package.

#### ham radio

##### oscillator/monitor specifications

|                         |  |
|-------------------------|--|
| <b>frequency range:</b> | 100 kHz to 1000 MHz  |
| <b>sensitivity:</b>     | 10 mW without direct connection to the unit  |
| <b>applications:</b>    | rf detector, continuity, component, and semiconductor tester, CW monitor, code practice oscillator |
| <b>semiconductors:</b>  | 4 transistors and 2 diodes   |
| <b>power required:</b>  | 1.5 V AA battery (furnished)   |
| <b>size and weight:</b> | 3 $\frac{1}{2}$ " H x 2 $\frac{3}{4}$ " W x 1 $\frac{1}{4}$ " D; 8 ounces                          |
| <b>price:</b>           | \$12.95 postpaid   |

# Sale



**STEREO  
PREAMP** **4.95**

- ★ 8 TRANSISTORS
- ★ Ready to Play thru tape Amplifier, radio, TV
- ★ Volume, Tone, Controls sw



**2N3235**  
NPN SILICON  
(Watts) 115  
BV CBO 100  
(AMP) 15 **\$2.25**

## FIELD EFFECT TRANSISTORS

**RAYTHEON** 2N3608  
"MOST" IGFET p-channel  
Input **2.99 ea.**  
10 million meg-

## GLASS ONE AMP SILICON RECTIFIERS

| PIV | Sale     | PIV | Sale |
|-----|----------|-----|------|
| 50  | 600      | 19¢ | 21¢  |
| 100 | 800      | 21¢ | 25¢  |
| 200 | 9¢ 1000  | 32¢ | 37¢  |
| 400 | 13¢ 1200 | 45¢ | 52¢  |

## 1 AMP MICROMINIATURE SILICON RECTIFIERS

| PIV | Sale | PIV  | Sale |
|-----|------|------|------|
| 50  | 5¢   | 600  | 20¢  |
| 100 | 7¢   | 800  | 25¢  |
| 200 | 9¢   | 1000 | 32¢  |
| 400 | 12¢  |      |      |



## HAM SILICON TUBE SPECIALS

| (Replaces)      | Sale |
|-----------------|------|
| 1N1238 5U4GB)   | 2.39 |
| 1N1239 5R4)     | 4.39 |
| 1N1237 0Z4)     | 2.39 |
| 1N1262 6AU4GTA) | 2.39 |
| 1N2637 866A)    | 9.99 |
| 3DG4)           | 2.39 |

## 400 mc NPN SILICON

**5 for \$1**  
**2N706**  
Watts | V<sub>cb</sub> | I<sub>h</sub> | I<sub>ma</sub>  
.5 | 30 | 10-300 | 150

## 1 AMP TOP HAT AND EPOXIES SILICON RECTIFIERS

| PIV | Sale | PIV  | Sale |
|-----|------|------|------|
| 50  | 5¢   | 800  | 21¢  |
| 100 | 7¢   | 1000 | 32¢  |
| 200 | 9¢   | 1200 | 45¢  |
| 400 | 11¢  | 1400 | 65¢  |
| 600 | 17¢  | 1600 | 75¢  |

**2000 PIV 1.5 A \$1**

## ONE WATT ZENER DIODES

| Volts | Volts | Volts | Volts |
|-------|-------|-------|-------|
| 5.4   | 12.   | 47.   | 82.   |
| 6.4   | 15.   | 50.   | 100.  |
| 8.2   | 22.   | 56.   | 120.  |
| 9.1   | 24.   | 68.   | 150.  |
| 10.   | 27.   | 75.   | 180.  |

**39¢**

## SILICON POWER STUD RECTIFIERS

| PIV  | 3A  | 6A  | 12A  | 55A  |
|------|-----|-----|------|------|
| 50   | .06 | .16 | .20  | .50  |
| 100  | .07 | .22 | .25  | .75  |
| 200  | .09 | .30 | .39  | 1.25 |
| 400  | .16 | .40 | .50  | 1.50 |
| 600  | .20 | .55 | .75  | 1.80 |
| 800  | .30 | .75 | .90  | 2.30 |
| 1000 | .40 | .90 | 1.15 | 2.70 |

| TRIACS* | PRV  | 6° AMPS | 8 AMPS | 16 AMPS | 25 AMPS |
|---------|------|---------|--------|---------|---------|
| AND     | 50   | —       | .42    | .61     | .79     |
|         | 100  | .85     | .59    | .89     | .95     |
|         | 200  | 1.35    | .89    | 1.15    | 1.25    |
|         | 400  | 1.95    | 1.29   | 1.69    | 1.75    |
|         | 600  | 2.60    | 1.95   | 2.65    | 2.75    |
| SCRS    | 800  | —       | 2.95   | 3.25    | 3.50    |
|         | 1000 | —       | 3.50   | 3.95    | 4.25    |

## 2 AMP SILICON RECTIFIERS • GLASS CAPS

| PIV | Sale | PIV  | Sale |
|-----|------|------|------|
| 200 | 12¢  | 1000 | 45¢  |
| 400 | 16¢  | 1200 | 59¢  |
| 600 | 19¢  | 1400 | 69¢  |
| 800 | 29¢  | 1600 | 89¢  |

SOLITRON DEVICES, INC.

## 5 AMP Epoxy Rectifiers

| PIV | Sale | PIV  | Sale |
|-----|------|------|------|
| 50  | 19¢  | 600  | 59¢  |
| 100 | 25¢  | 800  | 69¢  |
| 200 | 39¢  | 1000 | 79¢  |
| 400 | 45¢  |      |      |

## SUPER SPECIAL!

| 500 MIL   | PRV | Sale       |
|-----------|-----|------------|
| All Tests | 50  | 10 for 25¢ |
|           | 100 | 10 for 35¢ |
|           | 150 | 10 for 40¢ |
|           | 200 | 10 for 45¢ |
|           | 250 | 10 for 50¢ |
|           | 300 | 10 for 55¢ |

## 85 WATT

NPN Like 2N424  
SILICON **2 For \$1**

## 1 AMP 4000 PIV MICROMINIATURE SILICON RECTIFIERS

**2 AMP 1000 PIV SET OF 3**

Delco PNP 100Watt/15 AMP HiPower T036 Case! 2N441, 442, 277, 278, DS501 up to 50 Volts for **\$1.00**

100 MICROAMP PANEL METER **2.99 ea.**



GIANT SPRING CATALOG ON: PARTS RECTIFIERS TRANSISTORS SCRS ZENERS

TERMS: include postage. Rated, net 30 days. CODs 25%

## POLY PAKS

P.O. BOX 942H  
LYNNFIELD, MASS.  
01940

Made in U.S.A.  
D'Arsonval Meter Movement!

New! Originally designed to be used with radiation detector! Basic meter movement 100µA. 2 mounting holes for easy installation in panel. Size: 2 1/2 x 3/4". Mounting centers: 1-1/16". Ideal for builders, hobbyists, labs, etc. Hurry, at this fantastic price they won't last long!

ALL ITEMS GUARANTEED AS ADVERTISED OR YOUR MONEY BACK

## SOLID STATE—BROADBAND DOUBLE BALANCED MIXER

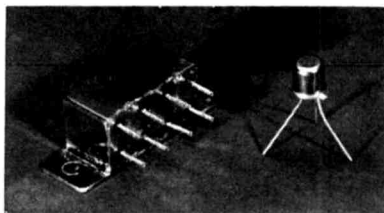

U.S.L. MODEL UM 1

Frequency Range ..... 200 kHz to 200 MHz  
 When Used in a 50 ohm System  
 Conversion Loss ..... 6 db Nominal; 7 db Maximum  
 Local Oscillator ..... 45 db 200 kHz to 30 MHz  
 Rejection ..... 35 db to 200 MHz

Replaces expensive and obsolete vacuum tube circuitry in a miniature R.F.I. package occupying less than 0.5 cubic inch.

P.C. card or chassis mount (indicate preference)

Applications Include:

- Balanced Modulator—Ideally suited for use in filter or phasing type S.S.B. generators.

- Receiver Mixer
- Product Detector
- Phase Detector

● Voltage Variable R.F. Signal Attenuator  
 State-of-the-Art performance and convenience offered by this broadband mixer are yours for only . . . \$15.00  
 (California residents add 5% Sales Tax)

SEND CHECK OR MONEY ORDER TO:

### ULTRAMATIC SYSTEMS LABORATORY

Post Office Box 2143  
 Sunnyvale, California, 94087

## COMPLETE YOUR GEAR TWENTY-FOUR CLOCKS IN ONE

NEW  
 AND  
 MODERN  
 AS THE  
 SATELLITE

**\$11.95**

Model D-300



## TIME ANYWHERE AT A GLANCE!

THROW YOUR CONVERSION CHART AWAY  
 When the clock is accurately set to the correct time in a local time zone, the correct time is automatically shown in each of the other 23 zones.

### Farmerie World Time-Zone Clock

CASE: wall or desk  
 22 ga. steel 8" x 8" x 23/4"  
 MOTOR: G-E 110-volt, 60 cycle  
 Other models available

### THE FARMERIE CORPORATION

114 Spencer Lane ■ Glenshaw, Penna. 15116

## HAM GEAR

## Q S L CARDS

## HOME BREW SUPPLIES

## HI-FI Components

## CABINETS

## ALL STANDARD SUPPLIES

**S** COTT RADIO SUPPLY, Inc.

266 ALAMITOS AVENUE  
 LONG BEACH, CALIF. 90802

## oscillator/monitor

- a sensitive broadband RF detector gives audible tone signal in the presence of any RF field from 10mw to 1 kw and 100kc to 1000mc
- a CW monitor with positive "RF" switch uses only 8" pickup antenna and NO connection to rig or key
- a code practice oscillator with adjustable tone & built in speaker
- high gain 4 transistor circuit powered by long life AA cell
- 16 gauge aluminum cabinet in white & black epoxy finish, 3 1/2" by 2 3/8" by 1 1/4", weight 8 ounces
- 100% US made and guaranteed

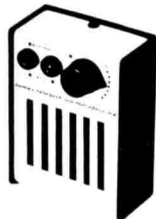

**12.95** (batt incl)  
 ppd usa & can  
 send cert ck or m.o.  
 ny res add 5% tax

the James research company  
 11 schermerhorn st., brooklyn n.y. 11201

### NOVICE CRYSTALS

Fundamental frequencies in FT-243 holders. Pin size .093 in., spacing .486 in. Tolerance .03% measured in oscillator with 92 mmfd. capacity.

|           |               |            |
|-----------|---------------|------------|
| 80 meters | 3705-3745 kc. | \$1.75 ea. |
| 40 meters | 7155-7195 kc. | 1.25 ea.   |
| 15 meters | 7034-7082 kc. | 1.25 ea.   |
| 2 meters  | 8056-8166 kc. | 1.25 ea.   |

Add for postage and handling per crystal: 8c first class; 12c airmail. Specify frequency desired and nearest available will be sent. Other frequencies in stock. Send for free list. Satisfaction guaranteed.

NAT STINETTE, P.O. Drawer Q-1, Umatilla, Fla. 32784



*"Your Friendly Supplier"*

**FROM STOCK! OFFERS**

A COMPLETE "LINE-UP" OF ACCESSORIES FOR THE HAM-SHACK

**EICO**

**Vibroplex**

**ASTATIC**

**AMÉCO**

MASTERCRAFTERS & PENNWOOD 24 HR CLOCKS

WELLER

**TRIMM**

**TURNER**

**COMDEL**

E. F. JOHNSON

JONES MICRO-MATCH

W2AU BALUNS

**B.W.**

**ElectroVoice**

**XCELITE**

**DOW-KEY**

... plus many more nationally advertised standard brands.

We maintain the largest stock of used equipment in the Northeast—Engineering Department—Time Payment Plan available.

WRITE FOR LATEST COMPLETE LIST

**Evans RADIO**

P. O. BOX 312 CONCORD, N.H. 03301

FONE 603-225-3358

**HAM TUBE SPECIALS!**

New — Guaranteed

|         |         |      |       |
|---------|---------|------|-------|
| 4CX250B | \$20.00 | 404A | 3.80  |
| 4CX350A | 25.00   | 866A | 1.50  |
| 4X150A  | 11.00   | 5881 | 1.75  |
| 4-1000A | 85.00   | 5894 | 14.00 |
| FG-17   | 4.50    | 6360 | 3.00  |
| 6907    | 16.00   | 6939 | 5.00  |

Top \$\$ paid for tubes

FREE—Ham tube catalog

120 W. 18th St., New York, N.Y.



10011

212-242-7400

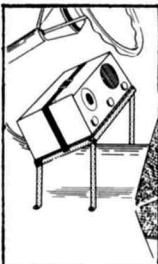

**TRANSCEIVER AUTO-MOUNT**

Easy tuning, accessible controls at knee height, in and out installation in a jiffy. Satisfaction guaranteed or a full refund.

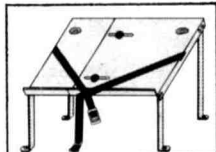

- Adjustable
- Fits all models
- Simple installation

**\$7.95**  
RETAIL

**ARCO MFG. CO.**

P. O. Box 817, Grand Forks, North Dakota 58201

**LOW PRICE, QUALITY, COAXIAL SWITCHES...**



Don't pay for the 5th and 6th position. The average HAM rarely uses more than 4!

SPECIFICATIONS: Silvered Contacts. Write-on ERASABLE escutcheon plate. AVAILABLE EITHER 4 PST (COAX-9) OR LINEAR (COAX-LINEAR) IN-OUT VERSION. Handles 1000 W AM or 2000 W SSB. Insertion loss negligible to 160 Mc. VSWR: Less than 1.2 at 160 Mc. Size: 3 3/8" dia. x 1 1/2" overall. Single hole mount. SPECIFY MODEL. \$7.65 ea.

**COAXIAL LIGHTNING ARRESTORS**



Zero power loss. No increase in SWR at 150 Mc. Does not alternate signals. Model 210 for 1000 W (AM) or 2000 W (SSB). Model 211 Electronic static arrester for 50 W (AM) or 100 W (SSB). SO-239 UHF type fittings. Other fittings available. Size approx. 3 1/2" x 3/4" dia. #210 \$3.15 ea. #211 \$4.65 ea. SPECIFY model #.

PRICES above are amateur net. Shipped ppd. in U.S.A. Send Check or M.O. (N.J. ADD 3% Sales Tax)

OTHER PRODUCTS: Feed thru capacitors. Tuned noise filters. Alternator, generator, low-pass and field filters. SEND FOR CATALOG.

**"COMMUNICATION ENGINEERED"**  
By "HAMMIE" RICHARDT—W2WIY

**ELECTRONIC APPLICATIONS CO.**  
ROUTE 46, Pine Brook, N. J. 07058

**CQ de W2KUW BEST OFFER!!**

Paid ..... for any piece of aircraft or ground radio units, also test equipment. All types of tubes. Particularly looking for 4-250 • 4-400 • 833A • 304TL • 4CX1000A • 4CX5000A et al. 17L • 51X • 390A • ARM • GRM • GRC • UPM • URM • USM units. TED DAMES CO., 308 Hickory St., Arlington, N.J. 07032

**WE PAY CASH FOR TUBES**  
**LEWISPAUL ELECTRONICS INC.**  
303 W. Crescent Avenue  
Allendale, New Jersey 07401

**GROUNDING GRID FILAMENT CHOKES**

10 Amp. \$3.00, 22 Amp. \$3.50, 30 Amp. \$4.00. Bifilar Wound, Ferrite Core, Size 3/4" x 5". Special sizes and current ratings available. PP con USA, Calif. add sales tax.

**William Deane, 8831 Sovereign Rd, San Diego, Calif. 92123**

# BUCK-TEN BAGS

## SILICON DIODES

| PIV  | 1 AMP | 12 AMP | 20 AMP | 40 AMP | 50 AMP | 100 AMP | 240 AMP |
|------|-------|--------|--------|--------|--------|---------|---------|
| 50   |       |        | .25    | .50    | .55    |         | 1.50    |
| 100  | .12   | .25    | .35    | .75    | .80    |         | 2.00    |
| 200  | .15   | .30    | .50    | 1.00   | 1.05   | 1.50    | 2.50    |
| 400  | .18   | .35    | .70    | 1.25   | 1.30   |         | 3.00    |
| 500  | .20   | .50    | .90    | 1.50   | 1.60   | 2.00    | 4.00    |
| 600  | .24   | .65    | 1.00   | 1.75   | 1.90   |         | 4.40    |
| 800  | .30   | .75    | 1.30   | 2.00   |        |         | 5.00    |
| 1000 | .35   | .90    | 1.40   | 2.35   |        |         |         |

|  |           |
|--|-----------|
| 2N670 Germ Audio. Gain over 100              | 10/\$1.10 |
| FET's mostly C610-C615 types. w/spec sheet   | 3/1.10    |
| 200 miniature glass diodes, unchecked        | 200/1.10  |
| 2N424 MESA 80 watt                           | 3/1.10    |
| CK-722, a real value                         | 6/1.10    |
| VARACTORS experimental pack w/sheet          | 20/1.10   |
| 2N2875 20 Watt Planar                        | 4/1.10    |
| 2N697 Hi freq 2 watt TO-5                    | 15/1.10   |
| 2N696 Hi freq 2 watt TO-5                    | 15/1.10   |
| VARACTOR 40 Watt sim to MA-4060A w/cir. ea.  | 4.00      |
| 1N251 Silicon diode, UHF mixer               | 20/1.10   |
| TO-5 Sil. power mix 2N498-2N546-2N549        | 10/1.10   |
| TO-3 Mix, 20-50 watt, 2N155-2N255            | 8/1.10    |
| MICRO TRANSISTOR Planar Epitaxial w/sht      | 25/1.10   |
| FLY SPECK transistor, micro miniature        | 8/1.10    |
| MICRO DIODE silicon                          | 20/1.10   |
| 2N706 Hi freq. 400 mc                        | 7/1.10    |
| BI-SWITCH make lamp dimmer etc. w/sheet      | 2/1.10    |
| 2N1417 Audio silicon NPN                     | 15/1.10   |
| 2N670 Silicon audio                          | 10/1.10   |
| 2N1059 NPN Germanium AF                      | 10/1.10   |
| 2N613 PNP Germanium AF                       | 8/1.10    |
| 2N404 Popular type PNP switching             | 6/1.10    |
| 2N414 PNP IF Germanium                       | 6/1.10    |
| 2N990 Germ. RF factory branded               | 6/1.10    |
| 60 WATT silicon 2N1208-2N1209-2N1210 types   | 3/1.10    |
| 4 WATT silicon Mesa 2N498                    | 4/1.10    |
| ZENER - 6 volt .2 amp                        | 4/1.10    |
| GERMANIUM diodes Cle vite EM-1               | 20/1.10   |
| IN82 Hi freq. mixer diode                    | 25/1.10   |
| TO-18 Hi-freq. switching RF transistors      | 25/1.10   |
| TO-5 Hi freq. switching RF transistors       | 25/1.10   |
| BI-DIRECTIONAL Silicon transistors           | 15/1.10   |
| 2N223 PNP germ AF, good gen. purpose         | 6/1.10    |
| 500 uufd Mica feed-thru button               | 15/1.10   |
| IBM MEMORY CORES w/spec sheet                | 200/1.10  |
| RESISTOR - MIX 100 units 1/2 watt            | 100/1.10  |
| DISC CERAMIC CAPACITORS, mixed               | 100/1.10  |
| 2000 volt 1 amp diode                        | ea/ .80   |
| 3000 volt 1 amp diode                        | ea/1.20   |
| REED SWITCH miniature glass                  | 6/1.10    |
| PHOTO-CELL resistive type                    | 2/1.10    |
| PHOTO-CELL, generates electricity            | 2/1.10    |
| SILICON DIODES 1/2 amp mixed voltages        | 15/1.10   |
| GEIGER COUNTER chassis, less tube            | 4.50      |
| INFRA RED viewing tube, see in dark, w/specs | 4.50      |
| AIR FORCE throat mike w/strap                | .60       |
| MICROPHONE, small spy type w/experiment sht  | 3/1.10    |

All above material shipped postpaid in the U.S.  
Send 25c for large catalog of many many interesting items.

Above transistors may be marked or unmarked.

**JOHN MESHNA JR 21 ALLERTON ST.  
LYNN MASS. 01904**

## advertisers' index

|                                       |            |
|---------------------------------------|------------|
| AMECO Equipment Corp. ....            | 88         |
| Antenna Specialists Co., The .....    | 53         |
| ARCO Manufacturing Co. ....           | 95         |
| Arrow Electronics, Inc. ....          | 84         |
| Ceco .....                            | 95         |
| Comdel, Inc. ....                     | 78         |
| Dames Co., Theodore E. ....           | 95         |
| Davco Electronics, Inc. ....          | 59         |
| Deane, William .....                  | 95         |
| Design Industries, Inc. ....          | 64         |
| Drake Co., R. L. ....                 | 2          |
| Electronic Applications Co. ....      | 95         |
| EIMAC a division of Varian .....      | 7          |
| Evans Radio .....                     | 95         |
| Farmerie Corp., The .....             | 94         |
| Galaxy Electronics .....              | Back cover |
| Gordon Co., Herbert W. ....           | Cover III  |
| Gotham .....                          | 73         |
| Hallicrafters Co., The .....          | 1          |
| Ham Radio Magazine .....              | 55         |
| Henry Radio Stores .....              | 89         |
| Hy-Gain Electronics Corp. ....        | 27         |
| James Research Co., The .....         | 94         |
| Lafayette Radio Electronics Corp. ... | 18         |
| Lewispaul Electronics Inc. ....       | 95         |
| Meshna, John Jr. ....                 | 96         |
| Moseley Electronics, Inc. ....        | 65         |
| Omega Electronics Co. ....            | 85         |
| Polygon Plastic Co., Inc. ....        | 90         |
| Poly Paks .....                       | 93         |
| Quement Electronics .....             | 19, 47     |
| Sanders Associates, Inc. ....         | 60         |
| Scott Radio Supply, Inc. ....         | 94         |
| Stinnette, Nat .....                  | 94         |
| Swan Electronics .....                | 39         |
| Ultramatic Systems Lab. ....          | 94         |
| Unadilla Radiation Products .....     | 79         |
| Waters Manufacturing Co. ....         | 8, 9       |
| World Radio Labs. ....                | Cover II   |

# One of Our Many Testimonials Concerning the Reginair Quad

| CALL | NAME    | TIME | MODE         | OTHER DATA   |
|------|---------|------|--------------|--------------|
| 0632 | KRAYD   | X    | 1420 5.9 5.9 | 1420 5.9 5.9 |
| 1420 | WABCA   | X    | 1420 5.9 5.9 | 1420 5.9 5.9 |
| 1420 | CP      | X    | 1420 5.9 5.9 | 1420 5.9 5.9 |
| 1420 | DL4CW   | X    | 1420 5.9 5.9 | 1420 5.9 5.9 |
| 0728 | DL1MS   | X    | 1420 5.9 5.9 | 1420 5.9 5.9 |
| 0840 | ZL1AA   | X    | 1420 5.9 5.9 | 1420 5.9 5.9 |
| 1134 | 1134    | X    | 1420 5.9 5.9 | 1420 5.9 5.9 |
| 1530 | LA8NK   | X    | 1420 5.9 5.9 | 1420 5.9 5.9 |
| 1600 | X       | X    | 1420 5.9 5.9 | 1420 5.9 5.9 |
| 1650 | X       | X    | 1420 5.9 5.9 | 1420 5.9 5.9 |
| 1745 | ONSKY   | X    | 1420 5.9 5.9 | 1420 5.9 5.9 |
| 1820 | CP      | X    | 1420 5.9 5.9 | 1420 5.9 5.9 |
| 1845 | CP      | X    | 1420 5.9 5.9 | 1420 5.9 5.9 |
| 1044 | 1044    | X    | 1420 5.9 5.9 | 1420 5.9 5.9 |
| 2015 | LD5UN   | X    | 1420 5.9 5.9 | 1420 5.9 5.9 |
| 2110 | DL4GF   | X    | 1420 5.9 5.9 | 1420 5.9 5.9 |
| 2235 | DL1AB   | X    | 1420 5.9 5.9 | 1420 5.9 5.9 |
| 2356 | DL2PU   | X    | 1420 5.9 5.9 | 1420 5.9 5.9 |
| 0550 | CP      | X    | 1420 5.9 5.9 | 1420 5.9 5.9 |
| 0940 | CP      | X    | 1420 5.9 5.9 | 1420 5.9 5.9 |
| 1570 | TEST    | X    | 1420 5.9 5.9 | 1420 5.9 5.9 |
| 1600 | LYNN    | X    | 1420 5.9 5.9 | 1420 5.9 5.9 |
| 1630 | PHIL    | X    | 1420 5.9 5.9 | 1420 5.9 5.9 |
| 0420 | IC8Z    | X    | 1420 5.9 5.9 | 1420 5.9 5.9 |
| 1510 | LA3UL   | X    | 1420 5.9 5.9 | 1420 5.9 5.9 |
| 1810 | DL1HP   | X    | 1420 5.9 5.9 | 1420 5.9 5.9 |
| 1540 | LYNP    | X    | 1420 5.9 5.9 | 1420 5.9 5.9 |
| 1745 | DL4EU   | X    | 1420 5.9 5.9 | 1420 5.9 5.9 |
| 1830 | CT1RA   | X    | 1420 5.9 5.9 | 1420 5.9 5.9 |
| 1630 | F52L    | X    | 1420 5.9 5.9 | 1420 5.9 5.9 |
| 1710 | G5TBF   | X    | 1420 5.9 5.9 | 1420 5.9 5.9 |
| 1820 | ON8BT   | X    | 1420 5.9 5.9 | 1420 5.9 5.9 |
| 1845 | CP      | X    | 1420 5.9 5.9 | 1420 5.9 5.9 |
| 1851 | CP      | X    | 1420 5.9 5.9 | 1420 5.9 5.9 |
| 0700 | Y5RFE   | X    | 1420 5.9 5.9 | 1420 5.9 5.9 |
| 0711 | YL2JL   | X    | 1420 5.9 5.9 | 1420 5.9 5.9 |
| 0805 | CP      | X    | 1420 5.9 5.9 | 1420 5.9 5.9 |
| 0800 | CA8CB   | X    | 1420 5.9 5.9 | 1420 5.9 5.9 |
| 1630 | JOE     | X    | 1420 5.9 5.9 | 1420 5.9 5.9 |
| 1735 | UL      | X    | 1420 5.9 5.9 | 1420 5.9 5.9 |
| 0850 | PT      | X    | 1420 5.9 5.9 | 1420 5.9 5.9 |
| 1605 | TKR     | X    | 1420 5.9 5.9 | 1420 5.9 5.9 |
| 1630 | WILLARD | X    | 1420 5.9 5.9 | 1420 5.9 5.9 |
| 1650 | TONY    | X    | 1420 5.9 5.9 | 1420 5.9 5.9 |
| 1700 | FINN    | X    | 1420 5.9 5.9 | 1420 5.9 5.9 |
| 1800 | GUY     | X    | 1420 5.9 5.9 | 1420 5.9 5.9 |
| 1847 | FRITZ   | X    | 1420 5.9 5.9 | 1420 5.9 5.9 |
| 1900 | PETER   | X    | 1420 5.9 5.9 | 1420 5.9 5.9 |
| 0750 | KEVIN   | X    | 1420 5.9 5.9 | 1420 5.9 5.9 |
| 0750 | KEVIN   | X    | 1420 5.9 5.9 | 1420 5.9 5.9 |
| 0851 | BILL    | X    | 1420 5.9 5.9 | 1420 5.9 5.9 |
| 0555 | JOE     | X    | 1420 5.9 5.9 | 1420 5.9 5.9 |
| 1555 | RUDY    | X    | 1420 5.9 5.9 | 1420 5.9 5.9 |
| 1605 | HAROLD  | X    | 1420 5.9 5.9 | 1420 5.9 5.9 |
| 1710 | WEN     | X    | 1420 5.9 5.9 | 1420 5.9 5.9 |
| 0630 | GEORGE  | X    | 1420 5.9 5.9 | 1420 5.9 5.9 |
| 1515 | BJORN   | X    | 1420 5.9 5.9 | 1420 5.9 5.9 |
| 1810 | HANS    | X    | 1420 5.9 5.9 | 1420 5.9 5.9 |
| 1545 | FRANK   | X    | 1420 5.9 5.9 | 1420 5.9 5.9 |
| 1800 | BEN     | X    | 1420 5.9 5.9 | 1420 5.9 5.9 |
| 1905 | EM      | X    | 1420 5.9 5.9 | 1420 5.9 5.9 |
| 1710 | EM      | X    | 1420 5.9 5.9 | 1420 5.9 5.9 |
| 1730 | MARK    | X    | 1420 5.9 5.9 | 1420 5.9 5.9 |
| 1835 | JOHN    | X    | 1420 5.9 5.9 | 1420 5.9 5.9 |
| 1850 | AHM     | X    | 1420 5.9 5.9 | 1420 5.9 5.9 |
| 1905 | REG     | X    | 1420 5.9 5.9 | 1420 5.9 5.9 |
| 0725 | KEN     | X    | 1420 5.9 5.9 | 1420 5.9 5.9 |
| 0745 | JULE    | X    | 1420 5.9 5.9 | 1420 5.9 5.9 |
| 0808 | OL      | X    | 1420 5.9 5.9 | 1420 5.9 5.9 |

OXBRIDGE MASS.  
Nov 27, 1967

Dear Herbs

THOUGHT YOU MIGHT BE MILDLY INTERESTED IN THE RESULTS I'VE HAD WITH YOUR REGINAIR 321 QUAD, SO I'VE ENCLOSED A PORTION OF MY LOG. THE CONTACTS THEREIN ARE NOT TERRIBLY RARE BUT WHEN YOU CONSIDER I'VE BEEN USING ONLY 60 WATTS DC IN ON 5SB, AND THE HEIGHT TO THE HUB IS ONLY 30', I HAVE TO SAY THAT YOUR QUAD MORE THAN LIVES UP TO THE CLAIMS MADE FOR IT.

THE VSWR IS FLAT OVER ALL BANDS & THE F/B RATIO IS EXCELLENT. A TRULY FANTASTIC ANTENNA

REGARDS  
Fred K1OKX

Only \$79.95  
F.O.B. Harvard, Mass.  
Shipping Weight 58 lbs.

The best item we have ever had and the best investment you can ever have is a darn good antenna! Nothing else will so improve your performance. The Reginair Model 321 Quad fully covers 10, 15, and 20 meters with less than 1 1/2 to 1 VSWR, requires but a single 50 ohm feed line and is remarkably easy to assemble, yet the introductory price is but \$79.95 FOB Harvard. Full details are available in our illustrated brochure. Send for your copy, or better yet, your Quad today.

HERBERT W. GORDON COMPANY  
Harvard, Mass. 01451, 617-456-3548  
"Helping Hams to Help Themselves"

**THE RECEIVER MAKES THE BIG DIFFERENCE!**

## Selectivity-

SHARP AS A RAZOR  
IN CUTTING OUT INTERFERENCE!

## Sensitivity-

PICKS UP EVEN  
THE WEAKEST SIGNALS!



THE GREAT NEW  
**GALAXY V**

**MARK 2**

**5 BAND-SSB  
TRANSCEIVER**

**MOBILE OR FIXED STATION**

**6 WAYS BETTER**  
Yet Still  
Only **\$420.00**

- New 400 Watt Power
- New Precise Vernier-Logging Scale
- New Solid State VFO
- New CW Sidetone Audio
- New CW Break-In Option
- New CW Filter Option

So much more Transceiver for the money—  
that it's only a matter of time before  
YOU own one!

*The best  
Features  
of any  
Transceiver—*

- Smallest of the High-Power Transceivers. (6" x 10¼" x 11¼").
- Great for either Mobile or Fixed Station. No Compromise in power.
- Hottest Receiver of any Transceiver — Special New Six-Crystal lattice filter.
- Complete 80-10 Meter Coverage. 500KC on all bands, with 1 Megacycle on 10 Meters.
- Both Upper and Lower Selectible Sideband.
- Highest Stability. Drifts less than 100 CY in any 15 minute period after warmup.
- The personal VFO stability chart of every Galaxy that comes off our line goes with the unit to its new owner!

See your nearest dealer—or write us for Free Brochure



**GALAXY ELECTRONICS**

*"Pacesetter in Amateur/Commercial Equipment Design"*

10 South 34th Street • Dept. HR-b2 • Council Bluffs, Iowa 51501